



UNITED NATIONS  
INDUSTRIAL DEVELOPMENT ORGANIZATION



# Technology Compendium for Energy Efficiency and Renewable Energy Technologies in Coimbatore Foundry Cluster

September 2020

**Disclaimer**

This document has been prepared to provide overall guidance for conserving energy and costs. It is an output of a research exercise undertaken by DESL supported by the United Nations Industrial Development Organization (UNIDO) and Bureau of Energy Efficiency (BEE) for the benefit of the Foundry units located at Coimbatore, Tamil Nadu, India. The contents and views expressed in this document are those of the contributors and do not necessarily reflect the views of DESL, BEE or UNIDO, its Secretariat, its Offices in India and elsewhere, or any of its Member States.

# Promoting Energy Efficiency and Renewable Energy in Selected MSME Clusters in India

*A GEF funded Project being jointly implemented by*



UNITED NATIONS  
INDUSTRIAL DEVELOPMENT ORGANIZATION



Technology Compendium for

## Energy Efficiency and Renewable Energy Technologies in Coimbatore Foundry Cluster

September 2020

Developed under the assignment

**Scaling up and expanding of project activities in MSME clusters**



Prepared by

**DESL**

**Development Environenergy Services Ltd**  
L-11-A, Plot No.C-001/A1, 11<sup>th</sup> Max Towers,  
Sector-16B, Noida - 201301  
Uttar Pradesh, (Delhi NCR)

## Acknowledgement

This assignment was undertaken by Development Environment Services Limited (DESL) as a project management consultant under the Global Environment Facility (GEF) funded project 'Promoting energy efficiency and renewable energy in selected MSME clusters in India.' The Technology Compendiums are meant to serve as an informative guide to the clusters that the project is currently working in and also to the other potential clusters across the country. DESL would like to express its gratitude to United Nations Industrial Development Organization (UNIDO) and Bureau of Energy Efficiency (BEE) for having provided the guidance in the completion of this assignment.

DESL would like to specially thank all the professionals for their valuable contributions in finalizing the different technology compendiums developed under the assignment. DESL is grateful to Mr. Abhay Bakre, Director General, BEE, Mr. R.K. Rai, Secretary, BEE and Mr. Milind Deore, Director, BEE for their support and guidance during the assignment. DESL would like to express its appreciation to Mr. Sanjaya Shrestha, Industrial Development Officer, Energy Systems and Infrastructure Division, UNIDO, for his support in execution of the assignment. We would like to thank Mr. Suresh Kennit, National Project Manager, and the entire Project Management Unit (PMU) for their timely coordination and valuable inputs during the assignment.

DESL would like to take this opportunity to thank all the MSME unit owners, local service providers and equipment suppliers for their active involvement and valuable inputs in the development of the technology compendiums. We extend our appreciation to the different Industry Associations in the clusters for their continuous support and motivation throughout the assignment.

Finally, we would like to thank each and every personnel from DESL team who have been actively involved at every step of the data compilation and whose tireless and valuable efforts made this publication possible.

**DESL Team**



# Contents

List of Figures .....	9
List of Tables.....	10
List of Abbreviations.....	11
Unit of Measurement.....	12
<b>About the Project .....</b>	<b>14</b>
<b>About the Technology Compendium .....</b>	<b>15</b>
<b>Executive Summary .....</b>	<b>16</b>
<b>1. About the Cluster.....</b>	<b>18</b>
1.1 Cluster overview.....	18
1.2 The Process .....	18
1.3 Technology status and energy use .....	19
<b>2. Technology 1: Replacement of Conventional Single Blast Cupola (SBC) Furnace with Divided Blast Cupola (DBC) .....</b>	<b>21</b>
2.1 Baseline Scenario .....	21
2.2 Energy Efficient Technology .....	22
2.3 Benefits of technology .....	22
2.4 Limitations of technology.....	22
2.5 Investment required, Energy & GHG saving potential & Cost Benefit Analysis .....	23
<b>3. Technology 2: Replacement of Cupola Furnace with Electric Induction Furnace.....</b>	<b>24</b>
3.1 Baseline Scenario .....	24
3.2 Energy Efficient Technology .....	24
3.3 Benefits of technology .....	24
3.4 Limitations of technology.....	25
3.5 Investment required, Energy & GHG saving potential & Cost Benefit Analysis .....	25
<b>4. Technology No. 3: Replacement of existing inefficient motors with IE 3 class energy efficient motors .</b>	<b>26</b>
4.1 Baseline scenario .....	26
4.2 Energy efficient technology.....	26
4.3 Benefits of technology .....	27
4.4 Limitations of technology.....	27
4.5 Investment required, Energy & GHG saving potential & Cost Benefit Analysis .....	27
<b>5. Technology No. 4: Installation of Solar Photovoltaic System for Power Generation .....</b>	<b>29</b>
5.1 Baseline Scenario .....	29
5.2 Energy efficient technology .....	29
5.3 Benefits of technology .....	29
5.4 Limitations of technology.....	29
5.5 Investment required, Energy & GHG saving potential & Cost Benefit Analysis .....	29
<b>6. No. 5: Replacement of Inefficient Blower with Properly Designed Blower .....</b>	<b>31</b>
6.1 Baseline Scenario .....	31

6.2	Energy efficient technology .....	31
6.3	Benefits of technology .....	31
6.4	Limitations of technology.....	31
6.5	Investment required, Energy & GHG saving potential & Cost Benefit Analysis .....	31
<b>7.</b>	<b>Technology No. 6: Replacement of Thyristor Based Induction Furnace with IGBT Induction Furnace</b> .....	<b>32</b>
7.1	Baseline Scenario .....	32
7.2	Energy efficient technology .....	32
7.3	Benefits of technology .....	32
8.4	Limitations of technology.....	32
7.5	Investment required, Energy & GHG saving potential & Cost Benefit Analysis .....	32
<b>8.</b>	<b>Technology No. 7: Implementation of Energy Efficient Compressed Air Distribution Network</b> .....	<b>34</b>
8.1	Baseline Scenario .....	34
8.2	Energy efficient technology .....	34
8.3	Benefits of technology .....	35
8.4	Limitations of technology.....	35
8.5	Investment required, Energy & GHG saving potential & Cost Benefit Analysis .....	35
<b>9.</b>	<b>Technology No. 8: Replacement of In-efficient Pump with EE Pump</b> .....	<b>38</b>
9.1	Baseline Scenario .....	38
9.2	Energy efficient technology .....	38
9.3	Benefits of technology .....	38
9.4	Limitations of technology.....	39
9.5	Investment required, Energy & GHG saving potential & Cost Benefit Analysis Cost benefits analysis.....	39
<b>10.</b>	<b>Technology No. 9: Energy Efficient Screw Compressor with VFD and PM motor</b> .....	<b>41</b>
10.1	Baseline Scenario .....	41
10.2	Energy Efficient Technology .....	41
10.3	Benefits of Technology.....	41
10.4	Technology Limitations .....	41
10.5	Energy & GHG emission saving potential, Investment required & Cost benefits analysis .....	41
<b>11.</b>	<b>Technology No. 10: Energy Efficient Lightings</b> .....	<b>43</b>
11.1	Baseline Scenario .....	43
11.2	Energy Efficient Technology .....	43
11.3	Benefits of technology .....	43
11.4	Limitations of technology.....	43
11.5	Energy & GHG emission saving potential, Investment required & Cost benefits analysis .....	43
<b>12.</b>	<b>Technology No. 11: Scrap Processing</b> .....	<b>44</b>
12.1	Baseline Scenario .....	44
12.2	Energy Efficient Technology .....	44
12.3	Benefits of technology .....	44
12.4	Limitations of technology.....	44
12.5	Energy & GHG emission saving potential, Investment required & Cost benefits analysis .....	44

<b>13. Technology No. 12: Replacement of Coil Cradle of Old Furnace.....</b>	<b>45</b>
13.1 Baseline Scenario .....	45
13.2 Energy Efficient Technology .....	45
13.3 Benefits of technology .....	45
13.4 Limitations of technology.....	45
13.5 Energy & GHG emission saving potential, Investment required & Cost benefits analysis .....	45
<b>14. Technology No. 13: Ladle Preheating .....</b>	<b>46</b>
14.1 Baseline Scenario .....	46
14.2 Energy Efficient Technology .....	46
14.3 Benefits of technology .....	46
14.4 Limitations of technology.....	47
14.5 Energy & GHG emission saving potential, Investment required & Cost benefits analysis .....	47
<b>15. Technology No. 14: Avoiding overfilling (metal above the coil level) of furnace during melting .....</b>	<b>48</b>
15.1 Baseline Scenario .....	48
15.2 Efficient Technology.....	48
15.3 Benefits of technology .....	48
15.4 Limitations of technology.....	48
15.5 Energy & GHG emission saving potential, Investment required & Cost benefits analysis .....	48
<b>16. Technology No. 15: FRP blades in cooling tower.....</b>	<b>49</b>
16.1 Baseline Scenario .....	49
16.2 Energy Efficient Technology .....	49
16.3 Benefits of technology .....	49
16.4 Limitations of technology.....	49
16.5 Energy & GHG emission saving potential, Investment required & Cost benefits analysis .....	49
<b>17. Technology No. 16: Lid Mechanism in Induction Furnace .....</b>	<b>50</b>
17.1 Baseline Scenario .....	50
17.2 Energy Efficient Technology .....	50
17.3 Benefits of technology .....	50
17.4 Limitations of technology.....	50
17.5 Energy & GHG emission saving potential, Investment required & Cost benefits analysis .....	50
<b>18. Technology No. 17: Automation of Heat Treatment Processes .....</b>	<b>52</b>
18.1 Baseline Scenario .....	52
18.2 Energy Efficient Technology .....	52
18.3 Benefits of technology .....	52
18.4 Limitations of technology.....	52
18.5 Energy & GHG emission saving potential, Investment required & Cost benefits analysis .....	52
<b>19. Technology No. 18: Replacement of Conventional Sand Plant with Energy Efficient Sand Plant.....</b>	<b>53</b>
19.1 Baseline Scenario .....	53
19.2 Energy Efficient Technology .....	53

19.3	Benefits of technology .....	55
19.4	Limitations of technology.....	55
19.5	Energy & GHG emission saving potential, Investment required & Cost benefits analysis .....	55
<b>20.</b>	<b>Technology No. 19: Installation of Automatic Power Factor Controller (APFC).....</b>	<b>56</b>
20.1	Baseline Scenario .....	56
20.2	Energy Efficient Technology .....	56
20.3	Benefits of technology .....	56
20.4	Limitations of technology.....	56
20.5	Energy & GHG emission saving potential, Investment required & Cost benefits analysis .....	56
<b>21.</b>	<b>Technology No. 20: Installation of Servo Voltage Stabilizer .....</b>	<b>57</b>
21.1	Baseline Scenario .....	57
21.2	Energy Efficient Technology .....	57
21.3	Benefits of technology .....	57
21.4	Limitations of technology.....	57
21.5	Energy & GHG emission saving potential, Investment required & Cost benefits analysis .....	57
<b>22.</b>	<b>Technology No. 21: Replacement 6-pulse power system with 12-pulse/24-pulse power system in induction furnace .....</b>	<b>58</b>
22.1	Baseline Scenario .....	58
22.2	Energy Efficient Technology .....	58
22.3	Benefits of technology .....	58
22.4	Limitations of technology.....	58
22.5	Energy & GHG emission saving potential, Investment required & Cost benefits analysis .....	58
	<b>Conclusion .....</b>	<b>60</b>
	<b>List of Vendors .....</b>	<b>61</b>



## List of Figures

Figure 1: Location of Coimbatore in Tamil Nadu .....	18
Figure 2: Process Flow .....	19
Figure 3: Share of energy usage in a typical small and medium foundry .....	19
Figure 4: Various zones of cupola furnace.....	21
Figure 5: Single blast cupola.....	21
Figure 6: Pictorial representation of single blast cupola (Source: www.fmc.org).....	21
Figure 7: Divided blast cupola.....	22
Figure 8: Pictorial representation of divided blast cupola.....	22
Figure 9: Cupola Furnace.....	24
Figure 10: Induction furnace.....	24
Figure 11: Energy efficient motor .....	26
Figure 12: IE efficiency classes for 4 pole motors at 50 Hz.....	27
Figure 13: Direct normal solar irradiance for coimbatore (kWh/m <sup>2</sup> /day) .....	29
Figure 14: Pictorial representation of ring main system .....	35
Figure 15: HDPE Pipelines.....	35
Figure 16: Compressed processed scrap.....	44
Figure 17: Ladle preheating system .....	46
Figure 18: Preheated ladle .....	46
Figure 19: Lid Mechanism in an Induction Furnace.....	50
Figure 20: Energy share of critical processes in foundry industry .....	53
Figure 21: Typical sand handling system in foundries.....	53
Figure 22: Comparison between bucket elevator plant and belt conveyor plant for sand handling .....	54
Figure 23: APFC Panel.....	56
Figure 24: 3 Phase 6 Pulse System .....	58
Figure 25: 6 Phase / 12 Pulse System .....	58
Figure 26: 12 Phase / 24 Pulse system.....	58

## List of Tables

Table A: Energy efficient and renewable energy technologies for Coimbatore Foundry Cluster .....	17
Table 1: Cost of various forms of energy in Coimbatore foundry cluster.....	20
Table 2: Rated parameters of present single blast cupola.....	22
Table 3: Cost benefit analysis of replacing present single blast cupola with EE DBC .....	23
Table 4: Cost of melting – cupola vs induction .....	24
Table 5: Cost benefit analysis of replacing cupola with induction furnace.....	25
Table 6: Rated parameters of present FD fan motor .....	26
Table 7: Specification of a 22 kW energy efficient motor.....	27
Table 8: Motor efficiency values as per IEC 60034-30.....	27
Table 9: Cost benefit analysis of replacing inefficient motor with EE IE-3 motor.....	28
Table 10: Cost benefit analysis of installing solar PV .....	30
Table 11: Cost benefit analysis for replacing inefficient blower with high EE blower.....	31
Table 12: Cost benefit analysis of replacement of induction furnace with IGBT.....	33
Table 13: Baseline parameters of compressor.....	34
Table 14: Cost benefit analysis of replacement of present pipelines with energy efficient compressed air distribution network.....	36
Table 15: Cost benefit analysis for CW pump replacement with EE pump and motor .....	39
Table 16: Cost benefit analysis for VFD Screw compressor with PM motor.....	42
Table 17: Cost benefit analysis of replacement of incandescent lighting with LED lighting .....	43
Table 18: Cost Benefit Analysis for in-house scrap processing .....	44
Table 19: Cost benefit analysis for a replacement of coil cradle .....	45
Table 20: Cost benefit analysis by avoiding overfilling of metals .....	48
Table 21: Cost benefit analysis for replacement of metallic/ aluminum blade with FRP blades in cooling tower .	49
Table 22: Cost benefit analysis for installation of lid mechanism in an induction furnace .....	50
Table 23: Cost benefit analysis for automation in heat treatment furnace .....	52
Table 24: Types of sand mixers.....	54
Table 25: Types of sand coolers for foundries .....	54
Table 26: Connected load for conventional vs EE sand plant.....	55
Table 27: Cost benefit analysis for energy efficient sand plant .....	55
Table 28: Cost benefit analysis of APFC panel.....	56
Table 29: Cost Benefit analysis of Servo Stabilizer.....	57
Table 30: Cost Benefit Analysis of 12 pulse/24 pulse power system in induction furnace .....	59

## List of Abbreviations

BEE	Bureau of Energy Efficiency
CCM	Continuous Casting Machine
COINDIA	Coimbatore Industrial Infrastructure Association
COFIOA	Coimbatore Foundry & Industries Owners Association
COSMAFAN	Coimbatore Tiny and Small Foundry Owners Association
DESL	Development Environergy Services Limited
EE	Energy Efficiency
EET	Energy Efficient Technologies
EIF	Electric Induction Furnace
GEF	Global Environment Facility
GHG	Greenhouse Gases
IFA	Indian Foundry Association
IIF	Institute of Indian Foundrymen
MNRE	Ministry of New and Renewable Energy
MoMSME	Ministry of Micro, Small and Medium Enterprises
MSME	Micro Small and Medium Enterprises
PHE	Plate Heat Exchanger
PMC	Project Management Cell
PNG	Piped Natural Gas
PV	Photovoltaic
RE	Renewable energy
RET	Renewable Energy Technologies
SBC	Single Blast Cupola
SPM	Special Purpose Machine
SPM	Suspended Particulate Matter
TANGEDCO	Tamil Nadu Generation and Distribution Corporation Limited
UNIDO	United Nations Industrial Development Organization

## Unit of Measurement

Parameters	UOM	Parameters	UOM
Ampere	A	Liter(s)	l
Approximate	~	Mega Joule	MJ
Centimeter	cm	Mega Watt Hour per Day	MWh/d
Centimeter Square	cm <sup>2</sup>	Meter	m
Cubic Centimeter	cm <sup>3</sup>	Meter cube	m <sup>3</sup>
Cubic Feet per Minute	CFM	Meter Cube per hour	m <sup>3</sup> /h
Cubic meter	m <sup>3</sup>	Meter cube per second	m <sup>3</sup> /s
Day(s)	d	Metric Ton	mt
Decibel	dB	Milligram	mg
Degree Centigrade	°C	Milligram per liter	mg/l
Degree Fahrenheit	°F	Millimeter	mm
Dry Bulb Temperature	DBT	Million	Mn
Giga Watt	GW	Million Tons of Oil Equivalent	MTOE
Giga Watt Hour	GWh	Minute(s)	min
Giga Watt Hour per Day	GWh/d	Normal Meter Cube	Nm <sup>3</sup>
Giga Watt Hour per year	GWh/y	Normal Meter Cube per Hour	Nm <sup>3</sup> /h
Gross Calorific value	GCV	Parts Per Million	ppm
Hertz	Hz	Per Annum	p.a.
Horse power	hp	Percentage	%
Hour(s)	h	Power Factor	PF
Hours per year	h/y	Revolution per Minute	rpm
Indian Rupee	INR or Rs	Rupees	Rs
Kilo Ampere	kA	Rupees per kilo Watt Hour	Rs/kWh
Kilo Calorie	kcal	Rupees per Metric Ton	Rs/mt
Kilo gram	kg	Second	s
Kilo Joule	kJ	Square Meter	m <sup>2</sup>
Kilo ton	kt	Standard meter cube	Sm <sup>3</sup>
Kilo volt	kV	Tesla	T
Kilo volt ampere	kVA	Ton	t
Kilo Volt Root Mean Square	kV rms	Ton of CO <sub>2</sub>	tCO <sub>2</sub>
Kilo watt	kW	Ton per Day	t/d
Kilo watt hour	kWh	Ton per Hour	t/h
Kilocalorie per kilogram	kcal/kg	Ton per Year	t/y
Kilogram	kg	Voltage	V
Kilogram per ton	kg/t	Watt	W
Kilogram per day	kg/d	Wet Bulb Temperature	WBT
Kilo volt	kV	Year(s)	y
Kilo volt root mean square	kV-rms	Year on Year	YOY



## About the Project

The United Nations Industrial Development Organization (UNIDO), in collaboration with the Bureau of Energy Efficiency (BEE), a statutory body under the Ministry of Power, Government of India, is executing a Global Environment Facility (GEF) funded national project titled 'Promoting energy efficiency and renewable energy in selected MSME clusters in India'. The project aims to develop and promote a market environment for introducing energy efficiency (EE) and enhanced use of renewable energy (RE) technologies in process applications in selected energy intensive industrial clusters, comprising micro, small and medium enterprises (MSMEs). The project is supported by the Ministry of Micro, Small and Medium Enterprises (MoMSME) and Ministry of New and Renewable Energy (MNRE). The project was operational in 12 MSME clusters across India in five sectors namely Brass (Jamnagar); Ceramics (Khurja, Thangadh and Morbi); Dairy (Gujarat, Sikkim and Kerala); Foundry (Belgaum, Coimbatore and Indore); Hand Tools (Jalandhar and Nagaur) in its first phase. The Project has now scaled-up and expanded its activities to additional 11 new clusters, namely in Dairy (Tamil Nadu, Odisha, Madhya Pradesh, Andhra Pradesh & Telangana, Haryana, Maharashtra & Punjab), Foundry (Ahmedabad & Howrah), Ceramic (Himmatnagar), Mixed Cluster (Indore & Sikkim) to reach out to MSME's at national level.

This project so far has supported 303 MSME units in implementing 603 Energy conservation Measures and thus resulted in reduction of about 10,850 TOE energy consumption and avoided 62,868 metric tons of CO<sub>2</sub> emissions as on date. The key components of the project include:

- Increasing capacity of suppliers of EE/RE product suppliers / service providers / finance providers
- Increasing the level of end user demand and implementation of EE and RE technologies and practices by MSMEs.
- Scaling up of the project to more clusters across India.
- Strengthening policy, institutional and decision-making frameworks.

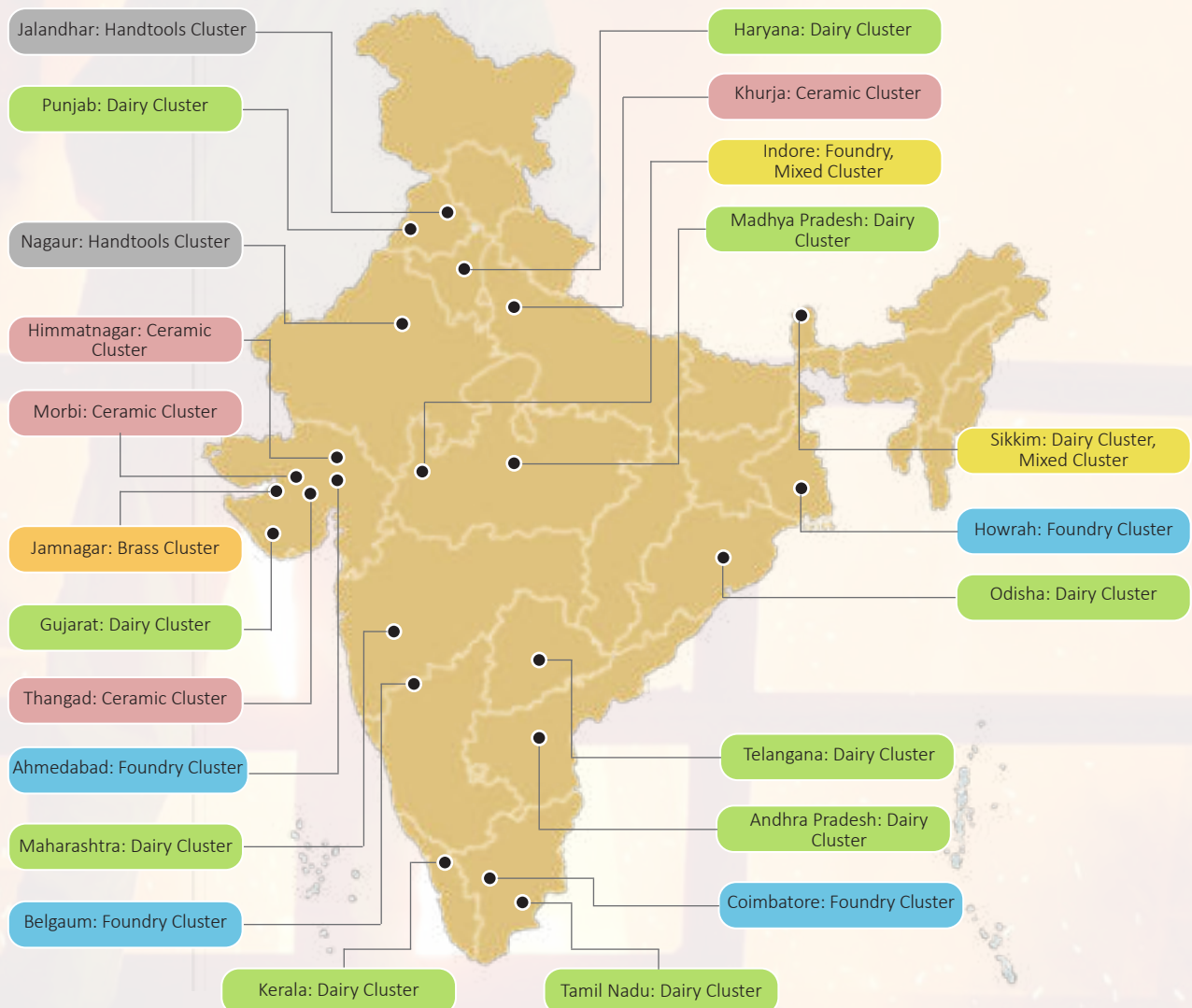

Clusters intervened by the project

## About the Technology Compendium

The Micro, Small and Medium Enterprises (MSME) sector in India are an important contributor to the country's economy. However, the sector faces challenges resulting from rising energy costs, environmental concerns and competitiveness. Most of the industries from the MSME sector use old and obsolete technologies leading to significant energy consumption. Studies show a significant potential in these units through adoption of energy efficient and renewable energy technologies.

The technology compendium has been prepared with the objective of accelerating the adoption of energy efficient and renewable energy technologies and practices applicable in the identified energy-intensive MSME sectors. The sector-wise technologies listed in the document consists of details about the baseline scenario, energy efficient alternatives available, advantages, limitations and cost benefit analysis for the same. The technology wise information is also supported by relevant case studies wherein benefits related to actual implementation of these technologies has been captured. Some notable points pertaining to the document are listed below:

- The compendium will act as a ready reckoner to the MSME units for continuously improving their energy performance leading to a cost-effective and sustainable production process.
- In the wide spectrum of technologies and equipment applicable for the sectors for energy efficiency, it is difficult to include all the energy conservation aspects in this manual. However, an attempt has been made to include more common implementable technologies across each of these sectors.
- The user of the compendium has to fine-tune the energy efficiency measures suggested in the compendium to their specific plant requirements, to achieve maximum benefits.
- The compendium also consists of a list of technology suppliers where the listed technologies can be sourced. However, in addition to the list provided in the compendium, there may be many more suppliers / consultants from where the technologies can be sourced.
- The technology compendium consists of list of energy efficient and renewable energy technologies under the broad categories of 'low investment', 'medium investment' and 'high investment measures'. Also due care has been taken to include technologies related to 'fuel switch', 'retrofit measures' as well as 'technology upgradation' options.
- The technologies collated in the compendium may not necessarily be the ultimate solution as the energy efficiency through technology upgradation is a continuous process and will eventually move towards better efficiency with advancement in technology.
- The document provides overview of the various available energy efficient and renewable energy technologies applicable in the targeted sectors. This provides an opportunity to the MSME units to implement the best operating practices and energy saving ideas during design and operations and to facilitate achieving world class energy efficiency standards.

## Executive Summary

The foundry industry is the one of the fast-growing industrial sectors in India, and one of the important industries having a bearing on the socio-economic development of the country. There are more than 5,000 foundry units in India, having an installed capacity of approximately 7.5 million tonnes per annum.

The majority (nearly 95%) of the foundry units in India fall under the category of small and medium sector enterprises (SMEs). The foundry industry is an important employment provider, with direct employment to about half a million people.

Coimbatore, located in the state of Tamil Nadu, is an important foundry cluster in Southern India. The foundry industry at Coimbatore came up mainly to cater to the needs of the local textile and pump-set industries. There are about 600 foundry units in Coimbatore. The geographical spread of the cluster includes Thanneer Pandal/Peelamedu, Ganapathy, SIDCO, Singanallur, Mettupalayam Road and Arasur Village.

Most of the foundry units cater to the needs of the domestic market. A small percentage (about 10%) of the foundry units is also exporting castings. Nearly half the number of foundry units is manufacturing castings for the pump-set industry. Cupola is the predominant melting furnace employed by the foundry units. Majority of the cupolas in the cluster are of conventional designs. Electric induction furnaces are used by around 25% of the foundry units, mainly to manufacture graded castings and for duplexing operation.

The Indian foundry industry is facing some developmental challenges to increase global competitiveness on the following fronts: capital expenditure, energy cost, availability of raw material, green technologies, and quality improvement.

Over the years, there has been significant technology improvement in process and utilities areas, and foundries have been able to improve the energy efficiency in their operations. However, the foundry sector can still be more competitive and environment-friendly in their operations, and energy efficiency is critical to achieve these goals.

The United Nations Industrial Development Organization (UNIDO) is playing a pivotal role jointly with the Bureau of Energy Efficiency (BEE), Ministry of Power, Government of India, towards scaling up the penetration of low-cost energy-efficient technologies (EETs) and renewable energy technologies (RETs) in the Coimbatore foundry cluster.

A total of 100 MSME foundry units in the cluster are envisaged to be supported technically to become energy efficient and cost-competitive.

This document is an outcome of the enormous research carried out in the sector, energy audits conducted in representation units and stakeholders' consultation conducted. The extensive research and ground-level deployment of various teams have made it possible to consolidate the list of energy-efficient and renewable energy technologies applicable for the Coimbatore foundry cluster. While most of these technologies have proven implementation records, some of the technologies are still in the developmental stages and will require efforts for implementation.

The compendium for energy-efficient and renewable energy technologies has been compiled and consolidated, keeping in mind different types and capacities of the foundry units.

This compendium can be used as a single point information booklet for various economically viable energy-efficient and renewable energy technologies applicable in the cluster. Each technology has been complemented by a techno-commercial analysis report; in order to provide the readers with in-depth understanding of the technology. Each technology comes up with information on tentative investment, energy-saving potential, cost savings and simple payback.

A vendor list has also been compiled at the end for easy reference of the units.

The technology compendium will act as a ready reckoner to the MSME unit owners and help them select relevant technologies for their units.

The technology compendium also consists of case studies on the actual implementation of the technologies and benefits realized thereof. Although the compendium consists of some general information on the technologies, the same will require customization based on individual units' requirements.

The Coimbatore foundry cluster has significant potential in terms of energy savings. The BEE-UNIDO project thus plays a pivotal role in making a transformational change in the sector which would lead to the units becoming cost-competitive; thereby resulting in a sustainable future.

The technologies identified for the sector have been categorized into three groups and comprise both energy efficient and renewable energy technologies applicable for the sector.



Table A: Energy efficient and renewable energy technologies for Coimbatore Foundry Cluster

Category	Description	Technology	Investment (Rs in Lakhs)	Saving Potential (Rs in Lakhs)	Simple Pay-back (Rs in Lakhs)
A	Low Investment Technologies (up to Rs 2 lakhs)	Replacement of old motors with IE-3 EE motors	0.15 -0.70	0.10 – 0.50	< 2 years
		Energy efficient blower	1 – 1.5	0.4 -0.6	< 2 years
		Energy efficient lightings	0.1-0.75	0.05-0.6	< 2 years
		Energy efficient compressed air network	1.5 -10	1 – 8	< 1.5 years
		Replacement of in-efficient pump with high EE pump	1 – 2.5	1.5 – 3	< 1 year
		Avoiding overfilling		2 -4	
		FRP Blades in cooling tower	0.5 – 1	0.6 – 1.1	< 1 year
		Lid mechanism in induction furnace	2.5- 4	3 – 5	< 1 year
B	Medium Investment Technologies (up to Rs 10 lakhs)	Energy efficient screw compressor with VFD and PM motor	3-15	4-20	< 1 year
		Scrap processing	5-15	2.5- 8	< 2 years
		Replacement of coil cradle	2-6	1-3	< 2 years
		Energy efficient ladle preheater	3-6	2 – 5	< 1.5 years
		Automation in heat treatment furnace	10-15	12- 20	< 1 year
		Installation of APFC	4-8	6 -10	< 1 year
		Installation of servo voltage stabilizer	10-15	10 -20	< 1 year
C	High Investment Technologies (more than Rs 10 lakhs)	Replacement of single blast cupola (SBC) with divided blast cupola (DBC)	15-25	10-20	< 2 years
		Replacement of cupola with induction furnace	50-80	15-30	< 3 years
		Installation of solar PV system	40-100	10-25	< 4 years
		Replacement of thyristor based induction furnace with IGBT based induction furnace	8-25	2-15	< 3 years
		Conversion from 6-pulse to 12-pulse / 24-pulse power system	20-30	10-18	< 2 years
		Energy efficient sand plant	25 – 100	8- 35	< 3 years

\*The figures on investment and savings are tentative and have been based on budgetary quotations and technical calculations; the actual figure may vary.

# 1 About the Cluster

## 1.1 Cluster overview

Coimbatore, located in the state of Tamil Nadu, is an important industrial cluster in India. The industrial activities in the cluster developed in the 1930s, with the setting up of many textile and spinning units. Initially, the metal casting industry flourished in Coimbatore to cater to the needs of the local textile machinery manufacturers. Subsequently, with the start of pump manufacturing in Coimbatore in 1930 and electric motors in 1937, it became an important cluster for manufacture of mono-blocks, domestic pumps and subsequently submersible pumps. In 1970s, wet-grinders were developed in Coimbatore for grinding of rice and lentils used in local recipes. The motor and drive-system of wet-grinders use casting components. Till date, the cluster is by far the largest producer of wet-grinders in India. Subsequently, major automobile manufacturing units came up in the state like Hyundai, Honda, Leyland, Allwyn, Nissan, Pricol, L&T, LMW and Mahindras.



(Source: [www.sameeksha.org](http://www.sameeksha.org))

**Figure 1: Location of Coimbatore in Tamil Nadu**

The setting-up of these automobile units created a great demand for castings as well. There are about 600 foundry units in Coimbatore cluster producing various products in various capacities. The foundry units are concentrated at Arasur, Annur, Avinashi Road, Ganapathy, Kanuvai, Mettupalayam, Peelamedu and SIDCO Industrial Estate. About 15 foundries are of large-scale, 70 of medium scale and the remaining could be grouped into small and micro categories. The production of castings of the cluster is about 2,000 tons per day (about 0.6 million tons per annum). The foundry industry provides about 10,000 direct employments. The estimated turnover of the foundries in the cluster is approximately Rs 3,400 crore per annum. Castings are also produced for other segments like Railways, Defense, petrochemicals, windmills and engineering industries.

Several foundry units in the cluster are of captive type, i.e. they produce castings for use in the end-products being manufactured by the firm for different end-use applications. There are also a number of jobbing foundries

which manufacture a diverse range of castings as per market orders. The cluster produces about 600,000 tons of casting per annum. The product share of automotive units is about 15%; pump-sets are 50%, wet-grinders are 10%, textile machineries are 10%, while jobbing foundries are 15%. (Source: [www.sameeksha.org](http://www.sameeksha.org)). There are various association in the clusters who work for the sector's development which includes COINDIA (Coimbatore Industrial Infrastructure Association), COSMAFAN (Coimbatore Tiny and Small Foundry Owners Association), COFIOA (Coimbatore Foundry & Industries Owners Association). Apart from these associations, the Institute of Indian Foundrymen (IIF) works to promote education, research, training and development in the foundry sector and serves as a nodal point of reference between the customers and suppliers of the Indian foundry industry on a global scale.

## 1.2 The Process

The major raw materials used include base metals (pig iron, steel, borings, scrap and foundry returns) and alloys (Ferro-silicon, Ferro-manganese, Iron Sulphide, Silicon Carbide, etc). In addition, small quantities of other metals like copper and tin are added for special grades and SG iron castings. Several of the foundries in the cluster are of captive type, i.e. they produce castings for use in the end-products being manufactured by the firm for different end-use applications. There are also a number of jobbing foundries which manufacture a diverse range of castings as per market orders.

The major steps of the foundry process are mould sand preparation, charge preparation followed by melting, pouring, knockout and finishing. The steps are explained below:

- Mould sand preparation: Fresh sand is mixed with bentonite and other additives and mixed in muller to make green sand.
- Moulding: The mould sand is pressed by machines or manually on the pattern to make the mould. Then the upper and lower halves of mould are assembled together to prepare the complete mould.
- Charging: The charged metallic such as pig iron, scrap, foundry returns and other alloys are weighted and charged in the furnace for melting.
- Melting: The metal charge is melted in either a cupola or induction furnace.
- Pouring: After melting, the molten metal is transferred and poured into the moulds using ladles operated either manually or with cranes.
- Knock-out: The moulds are left to cool for certain time

after which the castings are knocked-out from the mould either manually or using a machine.

- Finishing: The finishing operation involves removal of runners/risers, shot blasting and cleaning of castings.

The process flow diagram for a typical foundry unit is shown in the figure below:



Figure 2: Process Flow

From process point of view, cupola (SBC or DBC) furnace is the major energy consuming equipment followed by motor driven (or DG set driven) combustion air fans. A few units have baking (heat treatment) rooms where knocked out castings are heat treated by hot gases. These units use LPG or NG as fuel for heat treatment. In some units, heat treatment operation is done using electric induction furnace. In most of the units, moulds are prepared by hands. Only a few units use compressed air in their mould preparation process. Electric hand grinders are used for finishing operations for smoothening of finished casting surfaces.

### 1.3 Technology status and energy use

Coke and electricity are the major sources of energy for the foundries. The melting of raw material is either done using electricity in an induction furnace or coke in a cupola (conventional or divided blast type).

Induction furnaces operate on medium frequency, three phase electrical supply. The size of connected load of an induction furnace varies from 150 kg (100 kW) to 5 tons (2 MW). However, the most common specification of induction furnace used in foundry industry is 500 kg (550 kW). The theoretical electrical energy required for melting one ton of iron and heating up to 1,500°C is 396 kWh. In an induction furnace, a number of energy losses take place which increases the specific energy consumption to about 600–950 kWh per ton of product.

The capacity of cupola is generally indicated by the internal diameter of the shaft. Majority of the cupolas fall in the size range of 21 inch (2.2 t/h) to 40 inch (6 t/h). Cupolas are of two types based on blasting mechanism, i.e. conventional blast and divided blast. The metal tapping could be intermittent or continuous based on operation of foundry.

Preparation of the mould is an important process in casting industry. The mould is divided into two halves - the cope (upper half) and the drag (bottom half), which meet along a

parting line. Both mould halves are contained inside a box, called a flask, which itself is divided along this parting line. The mould cavity is formed by packing sand around the pattern (which is a replica of the external shape of the casting) in each half of the flask. The sand can be packed manually, but moulding machines that use pressure or impact to pack the sand are commonly used. Cores are placed inside the moulds to create void spaces. Cores are baked in ovens which are usually electrical fired.

Some foundries have installed a sand plant for sand preparation. The sand plant consists of sand

muller, sand mixer, conveyors, bucket elevators, knockout and sand sieve. Electricity is used to run these machines. Sand mixers have typical batch size of 200 to 1,000 kg. The connected load of these mixers is in the range of 10 to 100 kW.

Compressed air is mainly used to operate moulding machines, pneumatic grinders, mould cleaning and for other miscellaneous uses in a foundry. The connected load of an air compressor size may range from a few kW (single air compressor) for a small-scale cupola foundry unit to 55 kW (3-4 air compressors) for a medium-scale foundry having moulding machines.

Foundry uses two main forms of energy: coke and/or electricity. Melting accounts for a major share of energy ranging from 70-80% in a foundry unit. The other important energy consuming areas include moulding, core preparation and sand preparation.

The share of energy usage in a typical small and medium foundry is given in the figure below:

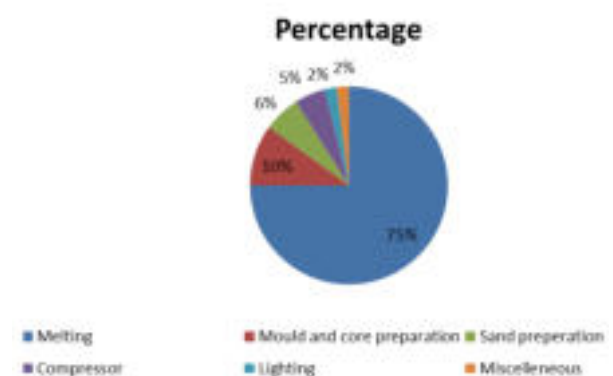

Figure 3: Share of energy usage in a typical small and medium foundry

The specific energy consumption (SEC) varies considerably in a foundry depending on the type of furnace and degree of mechanization. On an average, induction furnace based

foundry units consume about 1,000–1,200 kWh per ton of good castings. Out of this, about 600–700 kWh is consumed per ton of molten metal and the balance is consumed in other associated operations and in rejections and wastages. In cupola, the average coke consumption varies between 10-15% of the metal melted and 15-20% on good castings.

Grid electricity is sourced from Tamil Nadu Generation and Distribution Corporation Limited (TANGEDCO). Most of

the units have a standby diesel engine which is operated whenever there is breakdown in grid electricity supply. It was found that most of the units are equipped with very old and several times rewind induction motors which are consuming very high electricity, maybe a matter of consideration as far as energy efficiency is concerned.

The cost for different sources of energy, prevailing currently, has been tabulated below.

**Table 1: Cost of various forms of energy in Coimbatore foundry cluster**

Sl. No.	Parameter	UOM	Value
1	Grid electricity (LT connection) – energy charges	Rs/kWh	6.35
2	Grid electricity (LT connection) – demand charges	Rs/kW/month	70
3	Grid electricity (HT connection) – energy charges	Rs/kWh	6.35
4	Grid electricity (HT connection) – demand charges	Rs/kVA/month	350
5	Peak hour consumption for HT connection – 20% extra	Rs/kWh	1.27
6	Night hour consumption rebate – 5%	Rs/kWh	0.3175
7	Electricity tax	%	5
8	Average cost per unit – LT connection	Rs/kWh	7.0
9	Average cost per unit – HT connection	Rs/kWh	8.5
10	Coke (8-15% Ash content)	Rs/kg	25-35
11	Coke (26-32% Ash content)	Rs/kg	14-18
12	Diesel (For DG)	Rs /ltr	68

(Source: Cluster profile-Coimbatore developed by TERI)

# Technology 1: Replacement of Conventional Single Blast Cupola (SBC) Furnace with Divided Blast Cupola (DBC)

2

## 2.1 Baseline Scenario

Cupola furnace is the major equipment used in foundries in Coimbatore cluster. Most of the units presently operate a single blast cupola. The installed furnace is utilized for melting the raw material (pig iron, CI scrap and reject castings) to a tapping temperature of 1,300°C to 1,500°C. Furnace remains in operation for 2 to 3 days per week (approx. 100 to 150 days per year). During the operational days, the melting operation in cupola takes place for about 6-7 hours per day. Cupola is the most common type of melting furnace used for the production of grey iron castings. The process of the foundry units for melting the metal in cupola is summarized below:

Initially, coke is charged up to a predetermined height. This serves as the coke bed within which the combustion takes place. Cupola operation is started by igniting the coke bed at its bottom with the help of wood, and combustion air is supplied by blower (FD fan) which is mostly driven by a 3-phase, 415 volts induction motor. Most of the plants also have a stand-by FD fan which is driven by a diesel engine which operates during periods of power failure from electricity board.

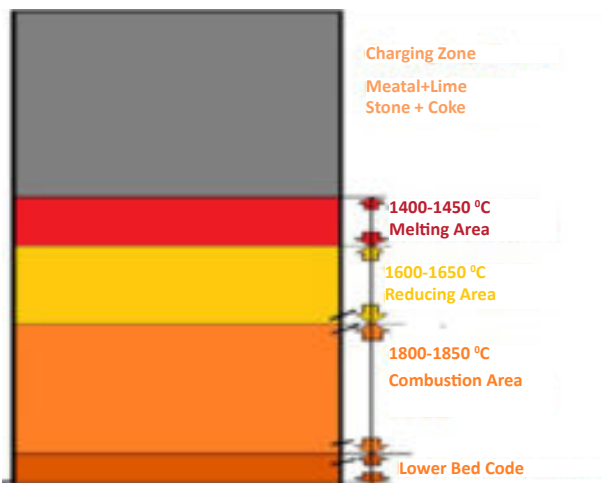

Figure 4: Various zones of cupola furnace

After proper ignition of coke bed, alternate charges of limestone, pig iron, scrap Cast Iron, rubbish metal and coke are charged. Hard coke is the fuel used and limestone is used as a flux to remove undesirable materials like ash, dirt and impurities from iron and protect iron from oxidation. The molten metal is obtained at the spout when the temperature inside the furnace reaches above 1,500°C. The molten metal is collected in ladle and poured in the mould and the mould is allowed to cool. In a cupola furnace, various zones exist based on reactions that take place inside the furnace due to combustion of metal, coke, limestone. The zones are charging zone (at top) where metal, limestone and coke are charged, melting area, reducing area, combustion area and

lower bed coke. The figure below shows the various zones and temperatures therein. The castings are obtained from mould after cooling and sent to clients.

In the process followed in the foundry units in Coimbatore cluster, the cupola furnace is the mother equipment. Most of the cupola used in Coimbatore are of 32" to 38" diameter and are of 5 to 12 t/batch (4-5 h/batch) capacity.



Figure 5: Single blast cupola

Most of them were installed in mid-90s and early 2000s. Many units still use the single blast cupola operation. Single blast cupola (SBC) is a furnace where air is supplied by the blower passes through one blast pipe, single wind box and two rows of tuyers.

Metal, coke and limestone are charged from the top charging zone and melting takes place as the temperature of the metal reaches about 1,100°C to 1,150°C. During melting, the molten metal flows through various zones in the cupola where its temperature increases further to about 1,400°C to 1,500°C and this molten metal is then tapped from the bottom in ladles which is then manually transferred and poured in moulds which are kept ready.

The inner shell of the cupola is lined with refractory bricks which are joined together using fire clay so that it can withstand the high melting temperatures of 1,500°C or higher. Due to high temperatures inside the cupola, the refractory linings are eroded due to wear and tear and excessive heat; so after each batch (or once in a week or 2 weeks) the maintenance work of cupola is done by using patching material (refractory pieces and fire clay) to cover the internal surfaces of the furnace which were eroded.

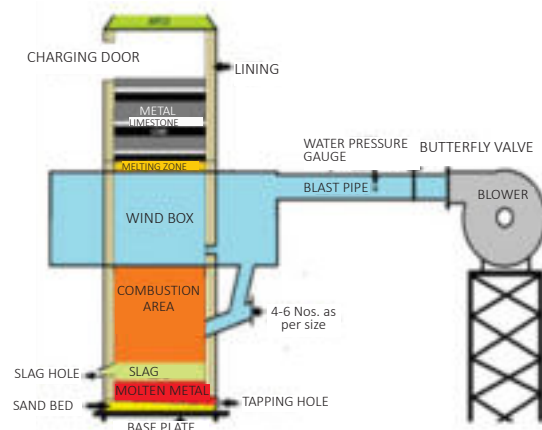

Figure 6: Pictorial representation of single blast cupola (Source: www.fmc.org)

Most of the single blast cupolas studied in the cluster are operating poorly and had a coke to metal ratio of 1:4 to 1:6 (maximum). Presently, there are more efficient cupolas using DBC which give much higher coke-metal ratio of 1:10 or higher. Some of the contributing factors that were identified for this poor energy performance are listed below:

- Incorrect blast rate
- Lower blast air pressure
- Incorrect distribution of air between the top and lower tuyeres
- Turbulent (non-linear) entry of air into the cupola
- Incorrect sizing of cupola parameters such as tuyere area, well depth, and stack height
- Poor operation and maintenance practices
- Poor control of feed materials (shape, size, weight, sequence)

The typical range of cupola furnace operating in the cluster is summarized below:

## 2.2 Energy Efficient Technology

It is suggested to replace the existing single blast cupolas with divided blast cupolas which are more efficient and so for the same production levels the unit will consume lesser coke and can obtain higher molten metal temperatures.



Figure 7: Divided blast cupola

Divided Blast Cupola (DBC) is a furnace where air is supplied by the blower passing through two sets of blast pipes, two wind boxes, and two rows of tuyeres. However, each set of tuyere is connected with separate wind box. Two sets of blast pipes divide the air from the blower and hence flow of air is controlled by butterfly valve installed on blast pipe. As compared to single blast cupola, it has been experienced that Divided Blast Cupola enables a higher metal tapping temperature and higher carbon pick-up for a given charge coke consumption.

## 2.3 Benefits of technology

Divided blast cupola (DBC) is a better and well-proven technology for improving the efficiency performance of the cupola furnace. Blast air is supplied to the DBC at 2 levels

Table 2: Rated parameters of present single blast cupola

Parameters	Annual capacity	Furnace Capacity	Coke-Metal ratio	Coke consumption	Hours of operation	Days of operation	Days of operation
UOM	t/y	T / d	%	t / d (1-batch)	h/d	d/week	d/y
	260-780	5-15	1:4 to 1:5	0.8 – 1.7	4-7	1-2	52-104

through a double row of tuyers. This blast air is equally divided between the top and bottom tuyere rows and the spacing between the tuyers are kept at 1 meter apart for all cupolas of various internal diameters.

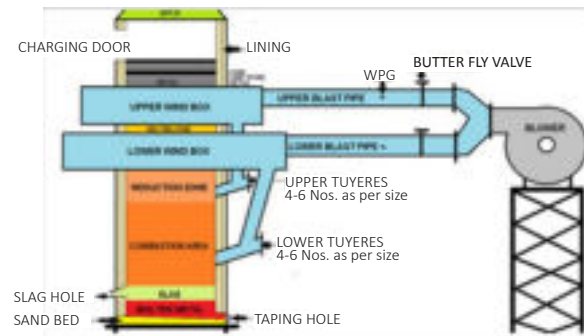

Figure 8: Pictorial representation of divided blast cupola

Some comparative advantages of a divided blast cupola are given below:

- A higher metal tapping temperature and higher carbon pick-up are obtained for a given charge –coke consumption
- Charge coke consumption is reduced by at least 25-30% and the melting rate is increased, while maintaining the same metal tapping temperature
- Optimum blower specifications (quality and pressure)
- Optimum ratio of the air delivered to the top and the bottom tuyeres
- Minimum pressure drop and turbulence of the combustion air separates wind-belts for top and bottom tuyeres
- Correct tuyere area, number of tuyeres, and distance between the two rows of tuyeres
- Higher stack height
- Mechanical charging system
- Stringent material specifications
- Higher coke to metal ratio (1:10 or higher)

## 2.4 Limitations of technology

The technology limitations for use of divided blast cupola (DBC) as compared single blast cupola (SBC) are as follows:

- Divided blast cupola (DBC) requires a higher capital investment compared to Single blast cupola (SBC).
- Divided blast cupola is not economically viable for larger castings.

## 2.5 Investment required, Energy & GHG saving potential & Cost Benefit Analysis

To understand the cost-benefit analysis from replacement of conventional single blast cupola with divided blast cupola, let us consider a unit having a single blast cupola 15 t/batch

capacity (avg. production of 3 t/h). The annual production of this unit is 1,200 t/y. The unit operates for 5 h/d and 80 d/y. Cost of hard coke (with <15% ash content) is Rs 30 / kg. The cost-benefit analysis for adoption of the technology is tabulated below:

**Table 3: Cost benefit analysis of replacing present single blast cupola with EE DBC**

Sl. No.	Parameters	Units	Single Blast Cupola (SBC)	Divided Blast Cupola (DBC)
1	Cupola Size	inch	32	32
2	Melting rate	t/h	3	3
3	Production capacity	t/batch	15	15
4	Annual Production	t/y	1,200	1,200
5	Specific casting rejection	kg of rejected casting/kg of molten metal	0.070	0.049
6	Coke to metal ratio	Ratio	1:7	1:10
7	Specific fuel consumption (SFC)	kg of coke/kg of molten metal	0.14	0.10
8	Ash percentage in coke	%	25	25
9	Conversion cost/ton of molten metal	Rs/t	2,000	
10	Cost/ton of fuel	Rs/t	30,000	
11	Saving in coke	t/y		48
12	Saving in rejection material	t/y		25.2
13	Monetary saving due to fuel	Rs. In Lakh/y		14.46
14	Monetary saving due to rejection	Rs. In Lakh/y		0.50
11	Total monetary saving	Rs. In Lakh/y		15
12	Estimated investment	Rs. In Lakh		20
13	Payback	y		1.33
14	Annual energy savings	toe / y		23
15	Annual GHG emission reduction	tCO <sub>2</sub> / y		197

\* Emission factor of coke taken is 3.0174 kgCO<sub>2</sub>/kg of fuel (as per IPCC 2006 V2; C1 & C2)

### Case Study 1: Installation of Divided Blast Cupola

Bharat Engineering Works, Howrah, West Bengal is a leading manufacturer of heavy, tailor-made castings with presence over four decades in the industry. With their head office based in Kolkata, the plant manufactures and exports a wide range of customized, graded Ferrous Castings, Ferro Alloys, and premium quality Raw Materials to more than 32 countries across the globe. With support from TERI, the unit replaced their existing single blast cupola with an energy efficient divided blast cupola (DBC). The new DBC showed a significant reduction in the energy consumption compared with the existing cupola. The CFR (Coke feed ratio) in the latter was 13.6% (coke: metal::1:7.5), whereas the DBC yielded a CFR of 8% (coke: metal::1:12.5). Hence, the energy saving achieved by the new plant was about 40% compared to the earlier cupola. The DBC also yielded additional benefits in terms of an increase in metal temperature and a substantial reduction in silicon and manganese losses.

On an average monthly melting of 430 tonnes, the DBC yielded an annual saving in coke of 270 tonnes, equivalent to 900 000 rupees (assuming a price of 3300 rupees per tonne for high ash Indian coke). The payback period worked out to be less than two years on the investment in the DBC alone.

Sl. No.	Particular	UOM	Baseline	Post Implementation
1	Average monthly production	Tonnes	430	430
2	Coke to Metal Ratio	Ratio	1:7.5	1:12.5
3	Annual coke saving	Tonnes		270
4	Annual monetary savings	Rs in Lakhs		9
5	Investment	Rs in Lakhs		15
6	Payback	y		1.66
9	Annual energy savings	toe/y		94.5
10	Annual GHG emission reduction	tCO <sub>2</sub> /y		814

\*Emission factor of coke as per IPCC guidelines 2006 (V2: C1 & C2) is 3.0174 kg CO<sub>2</sub>/kg of fuel

\*\*Source: Training manual for energy professionals in foundry sector published under BEE-World Bank-GEF project -2011 (Implementation done by TERI)

# 3

## Technology 2: Replacement of Cupola Furnace with Electric Induction Furnace

### 3.1 Baseline Scenario

Cupola furnace is the key technology used for production of grey iron castings in most foundry clusters. Cupola is utilized for melting the raw material (pig iron, CI scrap and reject castings) to a tapping temperature of 1,300°C to 1,500°C. Furnace remains in operation for 1 to 2 days per week (approx. 60 to 100 days per year). During the operational days, the melting operation in cupola takes place for about 6-7 hours per day (approx).



Figure 9: Cupola Furnace

Cupola is the traditional way of casting and the performance of the same is heavily dependent on the skills of the operator. The process is highly energy guzzling and leads to higher casting rejections. The operation of the cupola is dependent on the quality of coke. Also, diversity in terms of product is restricted.

In cupola furnace, close temperature control is not possible. Carbon and sulphur pickup takes place during melting (composition of cast iron affected). Loss of iron, silicon and manganese takes place during melting due to oxidation. Precise control of composition is difficult. High Environmental pollution is a headache for unit owners nowadays, as this cluster is almost in a densely populated residential area.

### 3.2 Energy Efficient Technology

It is proposed to replace the cupola furnace with energy efficient electric induction furnace. Many foundries around the world have implemented the latest advances in electric induction furnace (EIF) technology. In fact, evidence continues to accumulate regarding their inherent environmental friendliness, their ability to considerably reduce casting reject rates, and their impact on overall product quality improvement. Likewise, EIF implementations have reported up to 50 percent reduction in metal costs, due to reduced requirements of alloying elements and increased product yield, and labour cost reductions of up to 12 percent relative to cupola based operations. Encouraging results continue to

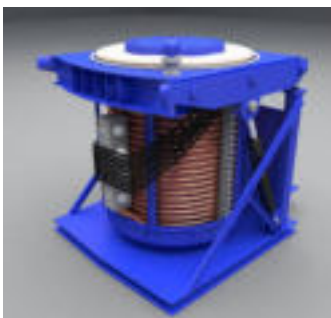

Figure 10: Induction furnace

be observed in a number of other similar EIF implementations done in recent times. Replacement of Cupola with EIF leads to environmentally cleaner operation and increased production. Induction furnace is best suited for ductile iron and steel melting which requires temperature in excess of 1,500°C, whereas for graded cast iron ( $\leq 1,450^\circ\text{C}$ ) both cupola and induction furnace can be used. Increase in demand, lack of skilled labour and ease of operation has made many foundries shift from cupola to induction furnaces, which is facilitated by equipment manufacturers and pollution boards.

In induction furnace, high frequency current is passed through water cooled copper coil. Secondary current are induced in the metal charge by electromagnetic induction. Metal charge offers resistance to the passage of secondary current that develops the requisite heat. Some of the advantages of induction melting vis-a-vis cupola are:

- Less oxidation of metal
- Relatively smaller area of metal is in contact with slag
- No carburizing during melting down
- Melting time less
- Excellent uniformity of the melt composition due to magnetic stirring of the metal
- Low pollution

The major disadvantage of induction furnace is high initial cost. It is also observed that production costs for CI castings are slightly higher by induction furnace method when compared to cupola. The specific energy consumption for melting (SEC) of induction and cupola furnace considered for analysis is presented in table below.

Table 4: Cost of melting – cupola vs induction

Particular	UOM	Value
Cupola Furnace	kg Coke/ton	200
Induction Furnace	kWh/ton	650

### 3.3 Benefits of technology

Replacement of cupola furnace with electric induction furnace leads to cleaner operating environment and a diversified production experience. The benefits of the technology can be listed as follows:

- Better temperature control
- Improvement in product quality
- Reduced casting rejects
- Low environmental pollution
- Reduction of metal cost due to costs, due to reduced requirement of alloying elements and increase of product yield
- Reduction of labor cost



### 3.4 Limitations of technology

The major disadvantage of induction furnace is high initial cost. It is also observed that production costs for CI castings are slightly higher by induction furnace method when compared to cupola. Implementation of electric induction furnace also leads to increase in connected load and demand charges.

### 3.5 Investment required, Energy & GHG saving potential & Cost Benefit Analysis

To understand the cost-benefit analysis from replacement of conventional single blast cupola/DBC with induction furnace, a case study of a foundry unit having a single blast cupola

of 120 t/monthly capacity (avg. production of 3 t/h) is considered. The annual production of this unit is 1,440 t/y. The unit is operating for 5 h/d and 104 d/y. Cost of hard coke is Rs 16/kg and cost of electricity is Rs 7/unit. The cost-benefit analysis for adoption of the technology is tabulated below:

So, as can be seen from the below table, although cost of melting for induction is higher than cupola, other benefits like reduced rejections, reduced electricity (blower) consumption, reduced manpower and other benefits like better quality, lower environmental pollution, etc. far out-weigh the higher melting costs; thereby making the switch-over from cupola to induction melting an efficient and overall cost saving option.

**Table 5: Cost benefit analysis of replacing cupola with induction furnace**

Sl. No.	Parameters	UOM	Cupola	Induction Furnace
1	Monthly Casting material (Production)	t/Month	120	120
2	Coke Consumption for Cupola (5 hours' operation/day)	t/Month	24	0
3	Electricity Consumption for Induction Furnace	kWh/month	-	75,000
3	Ash in Coke	%	31.3	31.3
4	Blower power consumption (26.1 kW motor rating)	kWh/month	1,344	0
5	Melt Temperature at spout	°C	1345 to 1478	1,500
6	Temperature of Flue gas (below charging door)	°C	306	60
7	Rejected Casting	%	8	2
8	Cost for melting Metal (CI)	Rs / t-molten metal	3,392	4,375
9	Cost involved for reject melting Metal (CI)	Rs / t-molten metal	2,560	640
10	Blower power consumption (26.1 kW motor rating)	Rs / t-molten metal	78.4	0
11	Manpower Cost for melting	Rs / t-molten metal	166.66	66.66
12	Total Cost of production	Rs / t-molten metal	6,197	5,082
13	Monetary cost savings for switching from Cupola To Induction	Rs/t		1,115
14	Annual Monetary Savings	Rs Lakh / y		16.06
15	Estimated investment	Rs Lakh		40
16	Simple Payback	y		2.49
17	Annual energy savings	toe / y		101.16
18	Annual GHG emission reductions	tCO <sub>2</sub> /y		492.32

\* Emission factor of coke taken is 3.0174 kgCO<sub>2</sub>/kg of fuel (as per IPCC 2006 V2; C1 & C2)

### Case Study 2: Replacement of cupola with electric induction furnace

Shilpa Enterprises, Siroli, Maharashtra plant was operating with a cupola furnace. Cupola furnace installed in 2001 was used for melting metal and had a melting rate of 2.2 MT/hour. The cupola was operated at temperature 1465°C and molten metal (MS-grade) pouring temperature was around 1300-1350°C. The operating hours of the cupola was low around 3-4 day per week. The coal to metal ratio is 1:5.88 which was very less as compared to the design ratio (1:10). The production capacity of the plant was 3000 t/y. In 2006, the plant decided to replace the cupola with an energy efficient induction furnace of 1250 kW and 500 kg capacity. With the new system, the plant achieved a savings of Rs 27 Lakhs with an investment of Rs 80 Lakhs

Sl. No.	Particular	UOM	Baseline	Post Implementation
1	Annual Production	t/y	3,040	3,040
2	Annual energy consumption	kg/y; kWh/y	5,15,000	19,51,680
3	Annual fuel cost	Rs in Lakhs	170	143
4	Annual monetary savings	Rs in Lakhs		27
5	Investment	Rs in Lakhs		80
6	Payback	y		2.96
7	Annual energy savings	toe/y		12.4

\* Emission factor of coke taken is 3.0174 kgCO<sub>2</sub>/kg of fuel (as per IPCC 2006 V2; C1 & C2)

\*\*Source: Implemented under GEF-UNIDO-BEE project titled "Promoting energy efficiency and renewable energy in selected MSME clusters in India"

# 4

## Technology No. 3: Replacement of existing inefficient motors with IE 3 class energy efficient motors

### 4.1 Baseline scenario

Three-phase induction motors are widely used in foundry units in various applications such as the sand mixing plants, melting section, shot blasting and finishing sections. Three-phase induction motors have 2 main parts: the stator or the stationary part and the rotor or the rotating part. Stator is made by staking thin slotted highly permeable steel lamination inside a steel cast or cast iron frame. Windings pass through slots of stator. When a 3-phase AC current is passed through it, it produces a rotating magnetic field. The speed of rotation of the magnetic field is called as the synchronous speed.

The rotor similar to a squirrel cage is placed inside the magnetic field; current is induced in bars of squirrel cage which is shortened by end ring. In effect, the rotor starts rotating. To aid such electromagnetic induction, insulated iron core laminas are packed inside the rotor; such small slices of iron ensure that the eddy current losses are minimal. The rotor always rotates at a speed slightly less than the synchronous speed; the difference is referred to as slip. Rotational mechanical power is transferred through a power shaft. Energy loss during motor operation is dissipated as heat; so a fan at the other end helps to cool down the motor.

Motor efficiency is defined as the ratio of mechanical power output to electrical power input. In a foundry unit, conventional motors (of IE 1 rating or lower) are used with an efficiency range from 75 to 88% depending on the size. At times, motors fail and work of a unit may come to complete standstill and the units start their stand-by diesel engine driven FD fan. Motor failures could be attributed to mechanical or electrical failures. Causes such as improper voltage, voltage fluctuations, improper lubrication and damaged bearings lead to rise in motor winding temperature, and ultimately leading to failure. These electrical failures lead to the next obvious step, i.e. motor re-winding. The motor's efficiency further decreases with each re-winding campaign, as these are mostly carried out by unskilled workers. Normally, a unit carries out 7-8 times of motor rewinding within its life span of 10 years. Each rewinding campaigns leads to an efficiency drop by 1-2%.

### 4.2 Energy efficient technology

Compared to conventional motors, the efficiency of energy efficient motors (Premium Efficiency class-IE3), available in the market ranges from 80-95% depending on the size.

Energy efficient motors operate at higher efficiencies compared to conventional motors, due to the following design improvements:

- Stator and rotor copper losses constitute for 55-60% of the total losses. Copper losses are reduced by using more copper conductors in stator and by using large rotor conductor bars.
- Iron loss accounts for 20-25% of the total losses. Using a thinner gauge, low loss core steel and materials with minimum flux density reduces iron losses. Longer rotor and stator core length, precise air gap between stator and rotor also reduce iron losses.
- Friction and Windage losses constitute for about 8-10% of the total losses. Friction loss is reduced by using improved lubricating system and high quality bearings. Windage loss is reduced by using energy efficient fans.
- Stray load loss accounts for 4-5% of the total losses. Use of optimum slot geometry and minimum overhang of stator conductors reduces stray load loss.
- Conventional motors operate in a lower efficiency zone when they are loaded less than 60%. Efficiency of energy efficient motors drop when loaded less than 50%. However, the efficiency of energy efficient motors is always higher than conventional motors, irrespective of the loading.



Figure 11: Energy efficient motor

When old motors are rewound more than 5 times, energy efficient motors can be considered as an ideal replacement. The technical specification of 7.5 hp energy efficient motor is presented below:

The motor efficiency as per IEC 60034-30 for 2-pole, 4-pole & 6-pole at 50 Hz frequency is tabulated below:

The efficiency graph for 4-pole IE 1 to IE 4 class efficiency motors at 50 Hz frequency is shown below:

Table 6: Rated parameters of present FD fan motor

Parameters	Annual capacity (1 furnace)	Rated motor power	Motor Efficiency	Rewinding	Hours of operation	Days of operation
UOM	t/y	kW	%	Nos.	h/d	d/y
	260-780	15-22	75-88	5-6	4-7	52-104

**Table 7: Specification of a 22 kW energy efficient motor**

Sl. No.	Parameter	UOM	Value
1	Capacity of Motor	kW	22
2	Duty type	-	Continuous duty
3	Performance	-	Premium IE 3 class efficiency conforming to IEC: 60034-30.
4	Type of Motor	-	AC Induction
5	Motor Power	kW	22
6	Rated Voltage	V	415
7	PF	-	0.8
8	Frequency	Hz	50
9	Efficiency at full load	%	93

**Table 8: Motor efficiency values as per IEC 60034-30**

kW	2-Pole			4 Pole			6 Pole		
	Frame Size	Efficiency %		Frame Size	Efficiency %		Frame Size	Efficiency %	
		IE2	IE3		IE2	IE3		IE2	IE3
0.37	71	72.2	75.5	71	70.1	73	80	69	71.9
0.55	71	74.8	78.1	80	75.1	78	80	72.9	75.9
0.75	80	77.4	80.7	80	79.6	82.5	90S	75.9	78.9
1.1	80	79.6	82.7	90S	81.4	84.1	90L	78.1	81
1.5	90S	81.3	84.2	90L	82.8	85.3	100L	79.8	82.5
2.2	90L	83.2	85.9	100L	84.3	86.7	112M	81.8	84.3
3.7	100L	85.5	87.8	112M	86.3	88.4	132S	84.3	86.5
5.5	132S	87	89.2	132S	87.7	89.6	132M	86	88
7.5	132S	88.1	90.1	132M	88.7	90.4	160M	87.2	89.1
11	160M	89.4	91.2	160M	89.8	91.4	160L	88.7	90.3
15	160M	90.3	91.9	160L	90.6	92.1	180L	89.7	91.2
18.5	160L	90.9	92.4	180M	91.2	92.6	200L	90.4	91.7
22	180M	91.3	92.7	180L	91.6	93	200L	90.9	92.2

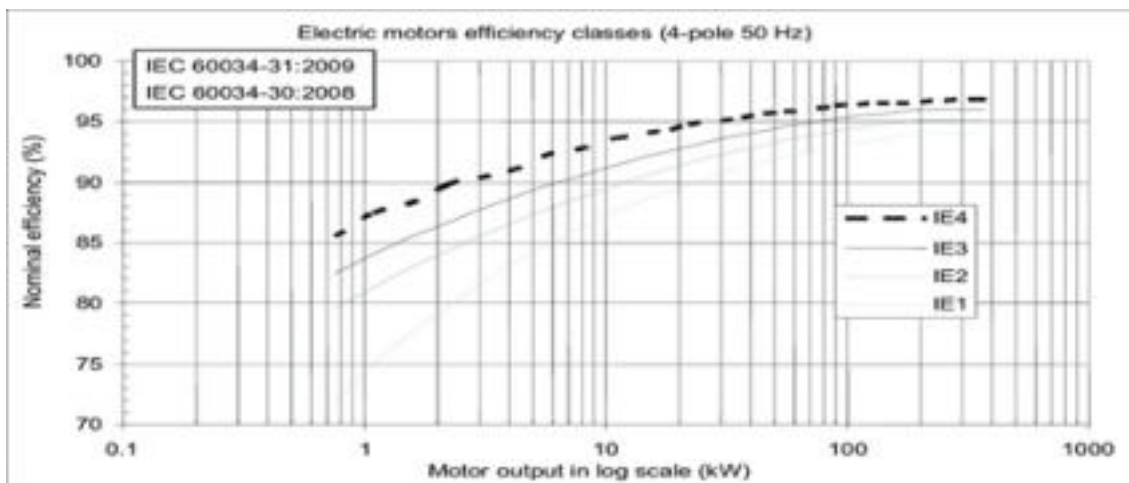

**Figure 12: IE efficiency classes for 4 pole motors at 50 Hz**

### 4.3 Benefits of technology

The implementation of IE 3 class efficiency motor in place of conventional motors leads to following benefits:

- Reduced specific energy consumption
- Lower breakdown
- Improved process efficiency
- Improved productivity
- Less operation and maintenance cost

### 4.4 Limitations of technology

An energy efficient motor requires a higher initial capital investment compared to conventional motors.

### 4.5 Investment required, Energy & GHG saving potential & Cost Benefit Analysis

To understand the cost-benefit analysis, let us consider a typical FD fan blower with the rated capacity of 22 kW. The unit operates for 360 hours per year. The cost-benefit analysis for adoption of the technology is tabulated below:

**Table 9: Cost benefit analysis of replacing inefficient motor with EE IE-3 motor**

Parameters	UOM	IE 1 class efficiency motor	IE 3 class efficiency motor
Number of motor	Nos.	1.0	1.0
Rated power of motor	kW	22.0	22.0
Operating power (Measured/Estimated)	kW	20.9	17.7
Operating hour per day	h/d	8.0	8.0
Operating days per year	d/y	120.0	120.0
Annual energy consumption	kWh/y	20,034	17,029
Annual energy saving	kWh/y	-	3,005
Electricity tariff	Rs/kWh	7.5	7.5
Annual monetary saving	Rs Lakh/y	-	0.25
Estimated investment	Rs Lakh	-	0.22
Simple payback period	y	-	0.88
Annual energy savings	toe/y	-	0.26
Annual GHG emission reduction	tCO <sub>2</sub> /y	-	2.70

\*Emission factor for electricity taken from IPCC guidelines 2006 (V2; C1 and C2) as 1 MWh = 0.9 tCO<sub>2</sub>

### Case Study 3: Installation of Energy Efficient Motors

Established in 1973, Sterling Cast & Forge is one of the leading manufacturer, supplier & exporter of hand tools & garden tools, tower pincers, water pump pliers, lock grip pliers, end cutting, nippers, long-nose, side cutter and carpenter pincer. Machining is one of the most energy intensive processes in the industry, which has a large number of motors of varied rated capacity.

The company took a significant step towards conserving energy by replacing their old motors with energy efficient IE-3 class motors. The unit installed one 4 kW, two 2 kW and three 1.5 kW IE-3 class efficiency motors in place of the existing 7.5 kW, 4 kW and 2 kW motors in the shank grinder, stone grinder and furnace blower respectively. The plant was able to make a reduction of 9 kW in the rated capacity, thus saving significantly in the production cost.

Parameters	UOM	Baseline	Post Implementation
Rated capacity of motors	kW	21.5	12.5
Annual operating hours	h/y	3,600	3,600
Reduction in rated capacity	kW		9
Annual energy consumption	kWh/y	61,920	36,000
Annual energy saving	kWh/y		25,290
Power tariff	Rs/kWh		7.5
Annual monetary saving	Rs in Lakh/y		1.94
Investment	Rs in Lakh		2.00
Simple pay-back	Months		12
Annual energy savings	toe/y		2.22
Annual GHG emission reduction	tCO <sub>2</sub> /y		23.33

\*Emission factor of Electricity as per IPCC Guideline 2006 (V2; C1 & C2) is 0.9 tCO<sub>2</sub>/MWh

\*\*Source: Implemented under GEF-UNIDO-BEE project titled "Promoting energy efficiency and renewable energy in selected MSME clusters in India"

# Technology No. 4: Installation of Solar Photovoltaic System for Power Generation

5

## 5.1 Baseline Scenario

Electricity is one of the key energy input components after coke in the Coimbatore foundry cluster where cupola is the major equipment. At a few units in Coimbatore where the melting is done by induction furnace, electricity is the major component of energy input. The units at Coimbatore cluster get power from the Tamil Nadu Generation and Distribution Corporation Limited (TANGEDCO). Power generated from fossil fuel based power plants is a threat for the country's natural resources as well as the environmental impacts. Switching over to renewable energy for power generation is an important contribution towards the country's sustainable development.

## 5.2 Energy efficient technology

Power generation using solar energy using a photovoltaic system is a sustainable alternative to survive in the growing competitive market environment. A photovoltaic system, also called as PV system or solar power system, is a power system designed to supply usable solar power by means of photovoltaic. It consists of an arrangement of several components, including solar panels to absorb and convert sunlight into electricity, a solar inverter to convert the output from direct to alternating current, as well as mounting, cabling, and other electrical accessories to set up a working system. It may also use a solar tracking system to improve the system's overall performance and include an integrated battery solution.

PV systems range from small, rooftop-mounted or building-integrated systems with capacities from a few to several tens of kilowatts, to large utility-scale power stations of hundreds of megawatts. Nowadays, most PV systems are grid-connected, while off-grid or stand-alone systems account for a small portion of the market.

The industries at Coimbatore cluster have a significant potential to generate power using solar photovoltaic

systems by either going for roof-top installation or ground mounted installation. Using a net metering system, the total electrical energy generation using photovoltaic system can be accounted for and deducted from the total grid supplied electricity.

The industries at Coimbatore have a potential to install 20 kW solar PV system within an area span of 200 m<sup>2</sup>. Average annual solar irradiation for Coimbatore, Tamil Nadu is 5.35 kWh/m<sup>2</sup>/day.

## 5.3 Benefits of technology

Adoption of solar photovoltaic system has the following benefits:

- Captive generation of electrical energy
- Clean and greener source of electricity
- Can be integrated with grid with net metering system
- Minimal operating and maintenance cost
- Long service life
- Only one time investment

## 5.4 Limitations of technology

Adoption of solar photovoltaic needs high capital investment. Generation of dust in the industrial area causes hindrance on the efficiency of the photovoltaic system. Installation of solar PV system on rooftop requires the structural strength, which needs to be analyzed as per site conditions.

## 5.5 Investment required, Energy & GHG saving potential & Cost Benefit Analysis

To understand the cost-benefit analysis, let us consider a solar PV system of 20 kWp capacity. The cost-benefit analysis for adoption of the technology is tabulated below:

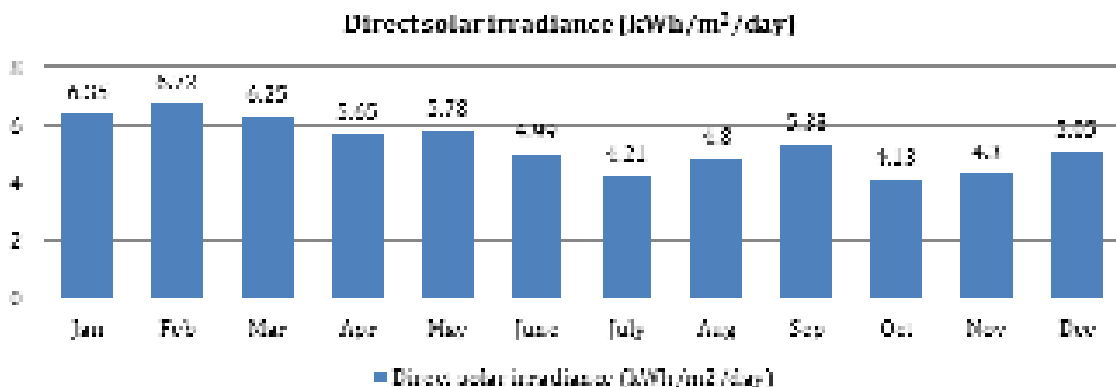

Figure 13: Direct normal solar irradiance for coimbatore (kWh/m<sup>2</sup>/day)

Table 10: Cost benefit analysis of installing solar PV

Sl. No.	Parameter	UOM	Value
1	Approx. Roof top area available	m <sup>2</sup>	200
2	Capacity of Solar PV system	kWp	20
3	Solar power generation capacity	kWh/kWp	3.5
4	Electricity generation potential from SPV (equivalent grid electricity will be displaced)	kWh/d	70
5	Annual solar radiation days	d/y	330
6	Electricity generation potential per year	kWh/y	23,100
7	Electricity charges	Rs/kWh	8.74
8	Annual monetary saving	Rs Lakh	2.02
9	Investment	Rs Lakh	8.00
10	Simple Payback	y	3.96
11	Annual energy savings	toe/y	1.99
12	Annual GHG emission reduction	tCO <sub>2</sub> /y	20.56

\*Emission factor for electricity taken from IPCC guidelines 2006 (V2; C1 and C2) as 1 MWh = 0.9 tCO<sub>2</sub>

### Case Study 4: Implementation of solar PV system

Rajhans Impex Pvt. Ltd. (RIPL) is an autonomous family run company, established in the year 2004. Since its inception, Rajhans Impex has sought to raise the bar in the brass extrusion industry. With modern manufacturing processes and technology, the company provides quality products and services. It has carved a niche in the industry by rapid innovation and prompt response to the market trends. As a result, today Rajhans Impex is a preferred name not only amongst domestic brass semis consumers but also among overseas consumers.

In 2018, the unit took an initiative to switch over to renewable energy for power generation. The unit installed a 220 kWp Solar Photovoltaic Roof top mounted system.

Sl. No.	Parameter	UOM	Value
1	Capacity of Solar PV system	kWp	220
2	Area covered	Sq. m.	2,200
3	Solar power generation capacity	kWh/kWp	4.5
4	Generation potential	kWh/d	990
5	Annual solar radiation days	d/y	365
6	Generation potential	kWh/y	3,61,350
7	Electricity charges	Rs/kWh	6
8	Annual monetary saving	Rs in Lakh	21.68
9	Investment	Rs in Lakh	100
10	Simple Payback	y	4.6
11	Annual energy savings	toe/y	31.07
12	Annual GHG emission reduction	tCO <sub>2</sub> /y	235.21

\* Emission factor for electricity taken from IPCC guidelines 2006 (Vs; C1 and C2) as 1 MWh = 0.9 tCO<sub>2</sub>

\*\*Source: Implemented under GEF-UNIDO-BEE project titled "Promoting energy efficiency and renewable energy in selected MSME clusters in India"

## Technology No. 5: Replacement of Inefficient Blower with Properly Designed Blower

6

### 6.1 Baseline Scenario

All cupola furnaces operating are equipped with electrical driven blowers that are always in operation; and most of them have a diesel engine operated blower as standby. The blowers are rated for 30 to 50 hp depending on the cupola rating. In conventional units, these blowers consume higher power than required and supply too little or sometimes much more air than required for proper combustion. The blowers are of local make and are not properly designed. The blower motors are also very old and several times rewind.

### 6.2 Energy efficient technology

The blowers must have proper flow rate and discharge pressure. It is proposed to replace the present blowers with properly designed blowers which would supply air at requisite pressure and flow rate so that optimum blast rate could be maintained and the cupola could be operated efficiently. The air flow to be supplied by the blower for maintaining optimum blast rate should be 375 cfm per square foot or 115 m<sup>3</sup>/min per square meter (cupola's internal diameter) (Source: Best operating manual: Belgaum Foundry cluster).

The blower must be rated for 15-20% more than the optimum blast rate to account for air losses in the pipeline. It should be noted that the blast rate must be optimum because higher blast rate would increase the oxidation loss of iron, silicon and manganese while lower blast rate would result in low metal temperature, higher melting time and higher coke consumption for same production levels. Along with optimum air flow, the air pressure being supplied by the blower should also match with the proper blast pressure that is required to penetrate the coke bed. Improper air penetration would also affect the temperature, carbon pick-up and melting rate of the cupola.

### 6.3 Benefits of technology

The replacement of inefficient blower with properly designed EE blower leads to following benefits:

- Optimum blast rate being maintained in cupola
- Optimum molten metal temperature
- Lower stack losses
- Higher melting rate (or lower melting time)
- Lower power consumption by blower
- Lower oxidation losses in the furnace
- Coke and electricity / diesel savings

### 6.4 Limitations of technology

Blowers for each unit must be designed for the required air flow and pressure based on the unit's cupola specification and production rates. For Coimbatore cluster, as the industries operate at much lower loads (than design) due to low demand, the EE blower may not always be working on its rated parameters. Cost of EE blower is also higher than the cost of local make blowers.

### 6.5 Investment required, Energy & GHG saving potential & Cost Benefit Analysis

To understand the cost-benefit analysis, let us consider a blower of 28.7 kW capacity. The cost-benefit analysis for adoption of the technology is tabulated below:

**Table 11: Cost benefit analysis for replacing inefficient blower with high EE blower**

Parameters	UOM	Conventional Blower	Energy Efficient Blower
Number of blowers	No.	1	1
Total measured power	kW	28.7	20.1
No of operating hours per day	h/d	8	8
Operating days per year	d/y	104	104
Average electricity consumption per year	kWh/y	23,878	16,723
Annual electrical energy savings	kWh / y		7,155
Cost of electricity	Rs / kWh		7.5
Annual monetary savings	Rs Lakh / y		0.53
Estimated investment	Rs Lakh		1.50
Simple payback period	y		2.83
Annual energy savings	toe / y		0.62
Annual GHG emission reduction	t CO <sub>2</sub> / y		6.44

\*Emission factor for electricity taken from IPCC guidelines 2006 (V2; C1 and C2) as 1 MWh = 0.9 tCO<sub>2</sub>

## 7

## Technology No. 6: Replacement of Thyristor Based Induction Furnace with IGBT Induction Furnace

### 7.1 Baseline Scenario

An induction furnace is an electrical furnace in which the heat is applied by induction heating principle to the metal. Capacity of an induction furnace ranges from less than one kilogram to one hundred tons capacity and is used to melt iron and steel, copper, aluminium and precious metals. Induction melting furnace is widely used in metal industry for melting or heating because of good heating efficiency, high production rate and clean working environment. Induction furnaces have very high power consumption and nonlinear characteristics.

A typical parallel resonant inverter circuit for induction melting furnace has a phase controlled rectifier that provides a constant DC current source. The inverter consists of four Thyristors and a parallel resonant circuit comprising capacitor bank and heating coil. Thyristors are naturally commutated by AC current flowing through the resonant circuit. The rated input voltage and frequency are 415 volt AC and 50 Hz. Major problems with thyristor based induction furnaces are the insufficient output power and frequent damage of the capacitor bank.

A typical foundry unit was operating a thyristor based induction furnace for melting. Pig iron, reject castings and scrap were the raw materials used. Furnace capacity was 750 kg/heat. The scrap was compressed as bales and fed into the furnace. The furnace was operating with specific electricity consumption (SEC) of 0.66 kWh / kg of metal melted (Present situation).

Furnaces with IGBT technologies can achieve better SECs in the range of 0.60 kWh/kg, which is the benchmark for such kinds of furnaces operating in India. Savings resulting by installation of new IGBT furnace would occur due to faster melting and better quality.

### 7.2 Energy efficient technology

Current source inverter (CSI) fed induction heating units are commonly used in the industry. Most of these CSIs are thyristor based. For high power and low frequency induction heating operation (where operating frequencies are less than 1 kHz), thyristor is good. But for the medium power and high frequency induction heating (where operating frequency up to 10 kHz), application of IGBT may be used to get better performance.

Insulated Gate Bipolar Transistor Technology (IGBT) is considered to be the most effective and efficient induction melting technology. IGBT is useful because of its high pulse rate. This high pulse rate allows the technology to generate large power pulses. Such large power pulses are necessary, especially in affecting the stirring action that is essential to metal melting.

Melting by induction is more cost-effective with use of IGBT

technology. Compared to thyristor based induction furnace, an IGBT induction furnace is more efficient and easier to operate. Energy losses are reduced in IGBT induction furnace, as furnace temperature control can be done easily and furnace will never heat the material higher than required temperature. Power factor maintained in IGBT is in the range of 0.95-0.98 when compared to less than 0.80 in case of thyristor based induction. In case of IGBT, the output capacitors are installed inside the generators itself, so no need to make any changes; while for thyristor type of furnace the output capacitors are installed near the transformer.

### 7.3 Benefits of technology

The replacement of thyristor based induction furnace with IGBT induction furnace leads to following benefits:

- Compensation-free in every operating condition, so there is no installation and maintenance costs of compensation
- Upgradable converter power with parallel module technology
- Simple replaceable power modules in case of trouble and service requirement
- Excellent coil protection system
- Probe-less automatic sintering
- Automatic crucible preheating
- Energy monitoring and consumption reporting via remote connection

### 8.4 Limitations of technology

Investment for IGBT furnace is much higher than thyristor based furnace.

### 7.5 Investment required, Energy & GHG saving potential & Cost Benefit Analysis

To understand the cost-benefit analysis, let us consider a thyristor based furnace of 750 kg melting capacity (in a MSME unit in another cluster). The cost-benefit analysis for replacement of the present furnace with an IGBT furnace is tabulated below:



Table 12: Cost benefit analysis of replacement of induction furnace with IGBT

Particulars	UOM	Thyristor based induction furnace	IGBT based induction furnace
Rated production	kg / heat	750	750
SEC	kWh / kg	0.66	0.60
Electricity consumption per heat	kWh / heat	495	450
Number of heats per day	heat / d	12	12
Electricity consumption per day	kWh / d	5940	5940
Number of working days per year	d / y	330	330
Electricity consumption per year	kWh / y	19,60,200	17,82,000
Electricity savings per year	kWh / y	-	1,78,200
Weighted average electricity cost	Rs / kWh	7.5	7.5
Energy cost savings per year	Lakh Rs/ y	-	13.36
Total Investment	Lakh Rs	-	25
Simple Payback period	y	-	1.87
TOE savings per year	toe / y	-	15.32
Annual GHG emission reductions	tCO <sub>2</sub> / y	-	160

\*Emission factor for electricity taken from IPCC guidelines 2006 (V2; C1 and C2) as 1 MWh = 0.9 tCO<sub>2</sub>

### Case Study 5: Implementation of IGBT based induction furnace

Established in 1985, Shree Ganesh Enterprise has gained success in the market by manufacturing a remarkable assortment of Brass Insert, Brass DP Parts, Brass Joint Socket, Brass Electrical Pins, etc. The unit has developed a well functional and spacious infrastructural unit where they manufacture these components in an efficient manner.

In 2018, the unit took an initiative to replace their old conventional thyristor based Induction furnace with new energy efficient IGBT induction furnace, which led to higher production at lower electricity consumption.

SI. No.	Parameter	UOM	Baseline	Post Implementation
1	Average Production per heat	T	0.3	0.3
2	Average Heat Time	minutes	75	70
3	Average number of heats in a day	heat/d	12	12
4	Specific Power Consumption	kWh/t	333.3	306.7
5	Total production	t/y	1,080	1,080
6	Annual Power consumption	kWh/y	360,000	331,200
7	Annual fuel saving	kWh/y	-	28,800
8	Power Tariff	Rs/kWh	-	7.5
9	Annual Monetary Saving	Rs in lakhs	-	2.16
10	Investment	Rs in lakhs	-	8
11	Simple Payback	y	-	3.7
12	Annual energy saving	toe/y	-	2.48
13	Annual GHG emission reduction	tCO <sub>2</sub> /y	-	25.92

\*Emission factor for electricity taken from IPCC guidelines 2006 (Vs; C1 and C2) as 1 MWh = 0.9 tCO<sub>2</sub>

\*\*Source: Implemented under GEF-UNIDO-BEE project titled "Promoting energy efficiency and renewable energy in selected MSME clusters in India"

## 8

## Technology No. 7: Implementation of Energy Efficient Compressed Air Distribution Network

### 8.1 Baseline Scenario

Compressed air is an essential energy source, with up to 70% of industries using it for some aspect of their operations. The component that connects everything together in a compressed air system is the piping.

Compressed air is one of the major utilities of foundry units, as they are used in several operations like shot blasting, moulding machines, mould cleaning, pneumatic grinders, etc. The compressed air is generated at 7.5 to 8 kg/m<sup>2</sup> by a single compressor or sometimes with 2 compressors running in parallel, generating compressed air which is stored in a common receiver tank. Tank volumes vary depending on the sizes of compressors.

The compressed air piping can make or break the profitability of an enterprise. Lost power through inefficient or faulty piping can wipe out the profit margin and give the competitors an advantage.

Types of compressors used in the plants were either screw type or reciprocating type. The compressors were powered by AC induction motors of capacities of 15-30 hp. The compressed air is generated by the compressor which is stored in receiver tank and from there it is distributed to the entire plant at individual user points by pipeline network. The pipelines used were of MS or GI material and their sizes varied from ½ inch to 2 inches.

Compressed air distribution involves a lot of compressed air leakages as evident from hissing sounds during lunch breaks or shift changes when most of the machines are shut down. The air leakage is one of the major energy losses in the compressed air system, as this results in wastage of air generated. In some units, the leakages were about 30-40% of total compressed air generated by the compressors. Major points of such leakages are pipe joints, bends, elbows, etc. Further, there are also pressure drops in the system due to friction loss in pipelines. This results in the compressors generating more air to make up for the air leaks and pressure drops, thus increasing energy consumption.

Planning the compressed air piping system is the last consideration when organizing a shop floor. Mostly, old and worn out Mild Steel piping are seen in MSME industries for carrying compressed air. Inefficient compressed air distribution

systems result in higher energy bills, lower productivity and decline in the performance of the air tool. Some important reasons for the compressed air line losses are:

- Loosely installed connectors and ageing pipes are the main reasons for leakages.
- Sharp angles impede the speed of flow, reducing pressure. A 90-degree bend can lead to 3 to 5 PSID of pressure loss.
- Moisture clogs nozzles, contaminating pipe material and creating rough surfaces. A rough surface in turn leads to pressure drop.
- Particle accumulation causes obstruction and blockage in the air stream leading to lower pressure downstream and back up pressure upstream.

### 8.2 Energy efficient technology

For reducing compressed air leakages in distribution network, the present leakage levels in the plant need to be quantified. For this, a leakage test needs to be conducted. During lunch breaks or during plant closure at late evenings, when all machines are stopped, the compressors need to be run and allowed to build up to cut-off pressure (usually 7.5 to 8.5 kg/cm<sup>2</sup>). The compressor fills up the entire pipeline by building up pressure during loading and when the desired working pressure is attained, it will cut-off (or unload). During unloading, the compressor motor usually runs at about 30% of loading power but does not supply air (it only performs dummy strokes). When the entire pipeline is pressurized at desired pressure, the compressor will unload and should remain unloaded as the air is not being used at end-user points. However, due to leakages in system, the line pressure will start to drop and once the pressure drops to cut-in point, the compressor would again start on-load to build up the pressure again in the pipelines. This cycle will keep on repeating and the loading and unloading times need to be recorded. From this, the % leakage in the system could be calculated using the below formula:

$$\% \text{ Leakage} = \left[ \frac{\text{Loading time}}{\text{Loading time} + \text{Unloading time}} \right] \times 100$$

The % leakage in a good pipeline distribution network should be below 8-10% of total generated air. But if the % leakage is higher, then it could be reduced by plugging the leakages and replacing the pipelines with low friction lines.

**Table 13: Baseline parameters of compressor**

Parameters	Rated compressor motor power	No. of compressors per unit	Rated FAD	Hours of operation	Days of operation
UOM	kW	%	m <sup>3</sup> / min	h/d	d/y
	11-22	2-3	1.5-3.3	8-10	300

The Ring main system is an Energy Efficient alternative in piping. The design includes a closed loop ring line around the area in which air consumption takes place. Branch pipes connect the loop to various consumption points. This provides uniform compressed air supply, despite heavy intermittent usage, as the air is led to the actual point of consumption from two directions. In installations where consumption happens far away from the compressor room, a separate main pipe is then routed to the furthest point.

As an alternative material, high density polyethylene or HDPE is increasingly finding its way for an efficient compressed air piping network. An HDPE pipe consists of three layers, the innermost layer being the polyethylene layers followed by a thin layer of aluminum and with an upper coating of polyethylene. The aluminum layer is bonded with the polyethylene layer using high quality adhesive.

The benefits of HDPE pipes over conventional metal pipes are:

- No corrosion, hence no rust in air flow.
- Smooth interior allows laminar flow.
- The pipes are lightweight, hence easy to transport and fit.
- Cutting is far easier than metal pipes.
- Plastic pipes can be glued together, which is less costly and quicker than welding metal.

Efficient compressed air network can help in limiting the leakages to desirable limits (less than 10%) and also avoid system pressure drops, as they have much smoother interiors, thus reducing frictional pressure drops in the system.

### 8.3 Benefits of technology

An efficient compressed air system can provide significant long-term benefits.

- Low pressure drop between the compressor and point of consumption.

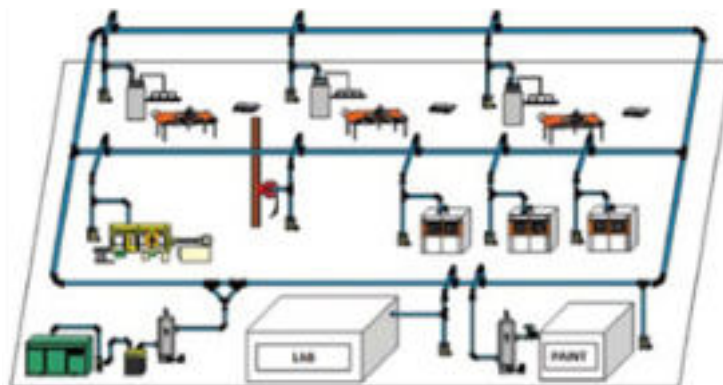

Figure 14: Pictorial representation of ring main system



Figure 15: HDPE Pipelines

- Minimum leakage from the distribution piping.
- Efficient condensate separation if a compressed air dryer is not installed.
- HDPE pipeline evolves out to be a better solution due to improved operating & maintenance conditions.

### 8.4 Limitations of technology

Investment for new HDPE pipelines is higher when compared to MS/GI pipes. It will also require constant monitoring and maintenance for system leakages arising out of wear and tear. Leakages will mostly occur at joints and bends and these should be replaced with spares as and when identified.

### 8.5 Investment required, Energy & GHG saving potential & Cost Benefit Analysis

To understand the cost-benefit analysis, let us consider a typical unit having screw compressors of 22 kW motor running. The compressor fills up the receiver from where the air is distributed to end user points by MS/GI pipelines. The compressors loads at 7 kg/cm<sup>2</sup> and unloads at 8.2 kg/cm<sup>2</sup>. The unit operates for 3,000 hours per year. The cost-benefit analysis for adoption of the technology is tabulated below:

**Table 14: Cost benefit analysis of replacement of present pipelines with energy efficient compressed air distribution network**

Sl.No.	Parameters	UOM	Existing system	Proposed system
1	Rated kW of compressor	kW	22.0	22.0
2	Rated cfm of compressor	cfm	117.9	117.9
3	Cut in Pressure	kg/cm <sup>2</sup>	7.0	7.0
4	Cut out Pressure	kg/cm <sup>2</sup>	8.2	8.2
5	Actual Free Air Discharge delivered	cfm	42.5	42.5
6	Actual Leakages in distribution lines	%	36.3	10.0
7		cfm	15.44	4.25
8	Present total power consumption by compressor	kW	20.73	-
9	Operating hours per day	h/d	10.00	10.00
10	Operating days per year	d/y	300.00	300.00
11	Reduction in compressed air leakages (Proposed)	cfm	-	11.19
12	Energy savings proposed by arresting the leakages	kW	-	5.46
13	Proposed annual energy savings	kWh / y	-	16,373
14	Wt. avg. cost of electricity	Rs / kWh	-	7.50
15	Proposed annual monetary savings	Rs Lakh / y	-	1.22
16	Proposed Investment	Rs Lakh	-	1.50
17	Payback period	y	-	1.23
18	Annual energy savings	toe / y	-	1.41
19	Annual GHG emission reduction	tCO <sub>2</sub> / y	-	14.74

\*Emission factor for electricity taken from IPCC guidelines 2006 (V2; C1 and C2) as 1 MWh = 0.9 tCO<sub>2</sub>



## Case Study 6: Implementation of energy efficient compressed air pipeline

Hariom Precision Alloys Private Limited, Alwar is one of the leading manufacturers of SG Iron and Grey Iron Casting in India. The company has adopted a quality management system & has acquired ISO: 9001:2000 certifications in the year 2002. The company is committed to produce quality goods along with complete customer satisfaction and also comply with Pressure Equipments Directive 97/23/EC for Pressure Equipment. Compressed air was a key element in the unit's production process. The plant had around 1,000 meters of compressed air line. Studies reported significant air loss due to leakage leading to higher energy consumption. In 2018, the unit revamped their entire compressed air network using state-of-the-art ring main system. Also, High Density Polyethylene (HDPE) pipelines were used. The benefits of HDPE pipes over conventional metal pipes are:

- No corrosion, hence no rust in air flow.
- Smooth interior allowed laminar flow.
- The pipes are lightweight, hence easy to transport and fit.
- Cutting is far easier than metal pipes.
- Plastic pipes can be glued together, which is less costly and quicker than welding metal.

The efficient compressed air system led to significant saving in terms of energy coupled with other benefits like low maintenance and longer life. There was significantly lower pressure drop in the compressed air network.

Parameters	UOM	Values	
		Baseline	Post Implementation
Existing Compressor Type		Reciprocating /Screw	Reciprocating /Screw
Rated Capacity	kW	45	45
Rated Capacity	hp	60	60
Rated cfm	cfm	250	250
Operating Pressure	kg/cm <sup>2</sup>	7	5
Power consumption (reduction in the delivery pressure by 1 bar in a compressor can reduce the energy consumption by 6 – 10 %)	kW	45	38
Annual operating hours	h	7,920	7,920
Electricity Tariff	Rs/kWh	7.5	7.5
Annual Energy saving	kWh/y	-	53,175
Annual Monetary Saving	Lakh Rs/y	-	3.98
Investment	Lakh Rs	-	7
Payback	y	-	1.75
Annual energy saving	toe	-	5
Annual GHG emission reduction	tCO <sub>2</sub>	-	48

\*Emission factor of Electricity as per IPCC Guideline 2006 (V2; C1 & C2) is 0.9 tCO<sub>2</sub>/MWh

\*\*Source: Energy audit carried out by DESL

## 9

## Technology No. 8: Replacement of In-efficient Pump with EE Pump

### 9.1 Baseline Scenario

Industrial pumps are used for a wide range of applications across many industries. Centrifugal pumps are the most preferred pumping devices in the hydraulic world. At the heart of the pump, lies the impeller. It has a series of curved vanes fitted inside the plates. When the impeller is made to rotate, it makes the fluid surrounding it also rotate. This provides a centrifugal force to the water particles to move radially out. Since rotational mechanical energy is transferred to the fluid, both pressure and kinetic energy of water will rise. As water gets displaced; a negative pressure is induced at eye. This negative pressure helps in sucking fresh water stream into the system again and this process continues. For proper operation, the pump is filled with water before starting.

Impeller is fitted inside a casing, so that water moving out will be collected inside it and move in the same direction of rotation of the impeller to the discharge nozzle. The casing has got increasing area along the flow direction. Such increasing area will help in accommodating freshly added water stream and also helps in reducing exit flow velocity. Reduction in flow velocity will result in increase in static pressure which is required to overcome resistance of pumping system.

The pump is driven by a motor. Improper selection of pump and its poor control mechanism leads to inefficient operations. The design of an efficient pumping system depends on relationships between fluid flow rate, piping layout, control methodology, and pump selection. Before a centrifugal pump is selected, its application must be clearly understood.

In typical foundry units, cooling water pumps are used for the cooling tower that circulate water to the plate heat exchanger (PHE) for cooling of induction furnace panels. Improper pump sizing and inefficient pumping system leads to very low system efficiency.

The low efficiency results in the pump consuming higher power and not being able to supply the required flow due to wear and tear of the impeller. Due to lower flow, the performance of the induction furnace is also affected. So, it is recommended to replace the inefficient pump with an energy efficient pump.

### 9.2 Energy efficient technology

Energy efficiency of a pumping system relates to selection of correct pump with required head and flow, based on application and its control mechanism.

- Features of energy efficient technologies include:

- Correct Impeller sizing: The circumferential speed of the impeller outlet depends on the impeller diameter. Trimming of impeller is done to match operating point with specification.
- Optimum blade angle: Vanes are curved backward inside the impeller. The blade angle should be properly designed for optimum efficiency.
- If pressure in suction side of the impeller goes below vapour pressure of water, water will start to boil forming vapour bubbles and spoil impeller material over time. This phenomenon is known as cavitations. More the suction head, lesser should be the pressure at the suction side to lift water. This fact puts a limit to the maximum suction head a pump can have. So, careful pump selection is required to avoid problems of cavitations.
- Pump curves also indicate pump size and type, operating speed (in revolutions per minute), and impeller size (in inches). It also shows the pump's best efficiency point (BEP). The pump operates most cost effectively when the operating point is close to the BEP.
- Variable Frequency Drives (VFDs) are usually the most efficient flow and/or pressure control option. The greater the speed reduction, the greater the energy savings.
- Automatic control with hydro-pneumatic system: Operation of pumps to be controlled based on set point pressure and pumping demand.
- Proper sealing arrangement to arrest leakages from the pump casing.
- Use of booster pumps in case of larger heads.
- Use of energy efficient motors directly coupled with pump.

### 9.3 Benefits of technology

The replacement of old inefficient pump with new EE pump has the following benefits:

- Higher flow
- Lower power consumption
- High operating efficiency
- Low operating costs
- Lower maintenance expenses for new pump
- Improved efficiency of induction furnace
- Higher productivity

### 9.4 Limitations of technology

Investment for new EE pump is higher when compared to non EE pumps. Also, selection of correct capacity of the pump and motor is important for optimum system efficiency.

### 9.5 Investment required, Energy & GHG saving potential & Cost Benefit Analysis Cost benefits analysis

The cost-benefit analysis from replacement of old inefficient pump with new EE pump of similar capacity is shown below.

**Table 15: Cost benefit analysis for CW pump replacement with EE pump and motor**

Description	UOM	Conventional Pump	Energy Efficient Pump
Discharge valve position	% open	100	100
Measured water flow	m <sup>3</sup> /h	124	124
Suction head	m	3.38	3.38
Discharge pressure	kg/cm <sup>2</sup>	4.30	4.30
Total head developed	m	39.63	39.63
Hydraulic power	kW	13.39	13.39
Pump shaft power	kW	29.77	17.85
Electrical power input to motor	kW	32.53	19.51
Pump efficiency	%	44.98	76.00
System efficiency	%	41.16	69.54
Estimated power savings	kW	-	13.28
Pump running hours	h/d	8	8
Pumps running days per year	d/y	330	330
Electrical energy savings	kWh/y	-	35,049
Cost of electricity	Rs/kWh	-	7.5
Monetary savings	Rs Lakh/y	-	2.62
Investment	Rs Lakh	-	1.67
Payback period	y	-	0.63
Annual energy savings	toe/y	-	3.01
Annual GHG emission reduction	t CO <sub>2</sub> /y	-	31.19

\*Emission factor for electricity taken from IPCC guidelines 2006 (V2; C1 and C2) as 1 MWh = 0.9 tCO<sub>2</sub>



### Case Study 7: Implementation of energy efficient pump

Integra Automation is a medium sector foundry unit located in Coimbatore region. Average monthly production of the unit is 1,000 MT. The plant installed an energy efficient multistage pump in place of an old centrifugal pump for circulating water to cool the induction coil of the furnace. Existing water pump for coil cooling had a pump efficiency of less than 60%; whereas energy efficient pump with IE3 motor led to a pump efficiency of 76.6%. Hence, coil cooling pump consumed lower power consumption than its earlier version.

Sl. No.	Parameter	UOM	Value
1	Energy Saving	kWh/y	33,120
2	Annual monetary saving	Rs in Lakh	2.48
3	Investment	Rs in Lakh	1.10
4	Simple Payback	y	0.45
5	Annual energy savings	toe/y	2.84
6	Annual GHG emission reduction	tCO <sub>2</sub> /y	29.80

\*\* Emission factor for electricity taken from IPCC guidelines 2006 (Vs; C1 and C2) as 1 MWh = 0.9 tCO<sub>2</sub>

\*\*Source: Implemented under GEF-UNIDO-BEE project titled "Promoting energy efficiency and renewable energy in selected MSME clusters in India"



**New EE Pump at Integra Automation**





## Technology No. 9: Energy Efficient Screw Compressor with VFD and PM motor

10

### 10.1 Baseline Scenario

Air compressors are used for a wide variety of applications in a foundry unit. In addition to its use in process application, compressed air finds its use in maintenance of most machines.

An air compressor is a power tool that creates and moves pressurized air. Air under pressure provides great force, which can be used to power many different kinds of tools. Conventionally, reciprocating air compressors, working by means of a piston and cylinder is the most commonly used compressor for industrial applications. When the machine is switched on, pressure changes suck air into the tank. The trapped air in the tank is placed under great pressure when the pistons move down. It is released by a discharge valve into another tank, where its release can be regulated and controlled through a valve. The valve discharges the pressurized air into space of its utilization. Pressurized air is measured in cubic feet, and the flow rate is measured in cubic feet per minute (CFM). A typical pressure rating for a small compressor used for industrial application is 7 kg/cm<sup>2</sup>.

Traditionally, in a foundry unit, the compressed air is produced by way of multiple reciprocating air compressors located at different locations in the unit. Often there are different reciprocating air compressors for each individual processes. These compressors produce a lot of noise with a relatively high cost of compression. The operational efficiency too varies, ranging from 22 to 35 kW/100 cfm. This goes down as the age of the equipment increased.

### 10.2 Energy Efficient Technology

With time, technology upgradation takes place leading to more efficient operations. An energy efficient alternative to the conventional reciprocating compressor is a high efficiency rotary screw compressor with direct coupled energy efficient motor and equipped with a Variable Frequency Drive, which can cater to fluctuating compressed air requirement.

Rotary screw compressors are operated with the basic principle of a positive displacement machine where key elements are a pair of spiral rotors. During operations, the rotors turn and the spiral keys mash together forming chambers between the rotors and the casing wall. Rotation causes the chambers to move from the suction or intake side to the compression or discharge side. These chambers are connected to the suction nozzle via ports. As the chambers enlarge, they are filled with air flowing in through the nozzle. The rotor transports the gas towards the discharge side where the chamber shrinks and thus the retained air is compressed.

Once the air is compressed, the chamber reaches another port connected to a discharge nozzle and the gas flows out. In fact, all the chambers between the two rotors are filled and emptied continuously. This means, that with the screw compressor, the compression process is more or less on-going. The design of a screw compressor combines the advantages of a positive displacement machine with those of a rotating machine making this type of compressor suitable for a wide range of requirements.

This type of compressor has only two moving parts which are not in contact with each other. There is, therefore, no friction and reduced possibility of breakdown. Moreover, the compressor works ceaselessly and produces much less noise when compared to the conventional reciprocating compressor. In addition to the design benefits of a rotary compressor, the VFD allows the operation of the compressor under variable load conditions, thereby saving energy. Also, the directly coupled energy efficient motor nullifies the transmission losses of a belt driven system and adds value in terms of the efficiency of the motor.

The operational efficiency of rotary screw compressor along with VFD and direct coupled energy efficient motor ranges from 16 to 19 kW/100 cfm.

### 10.3 Benefits of Technology

Advantages of screw compressor with VFD and directly coupled energy efficient motor include:

- 30-50 % reduction in specific power consumption of the compressor
- Noise free operation
- Longer compressor life
- Less maintenance.

### 10.4 Technology Limitations

Screw compressor with energy efficient motors and VFD is not economically feasible for very small capacity of compressed air demand. Also, for higher pressure application, a reciprocating or centrifugal type compressor is feasible.

### 10.5 Energy & GHG emission saving potential, Investment required & Cost benefits analysis

To understand the cost-benefit analysis, let us consider a 20 hp compressor with compressed air demand of 80-85 cfm with 7,920 hours of annual operation. The cost-benefit analysis for adoption of the technology is tabulated below:

**Table 16: Cost benefit analysis for VFD Screw compressor with PM motor**

Sl. No.	Parameters	UOM	Reciprocating compressor	Screw compressor
1	Design pressure	kg/cm <sup>2</sup>	8.0	8.00
2	Operating pressure (Compressor Panel Reading)	kg/cm <sup>2</sup>	7.0	7.0
3	Specific power consumption	kW/cfm	0.32	0.17
4	Average air required	cfm	69.0	69.0
5	Average power consumption	kW	22	11.7
6	Compressor capacity	cfm	85	-
7	Running hours per day	h/d	12	12
8	Annual operating days	d/y	300	300
9	Annual energy consumption	kWh/y	79,200	42,228
10	Annual energy saving	kWh/y	-	36,972
11	Weighted Avg. electricity cost	Rs/kWh	-	7.5
12	Monetary savings	Lakh Rs/y	-	2.77
13	Investment	Lakh Rs	-	8.00
14	Payback period	y	-	2.8
15	Annual energy saving	toe	-	3.2
16	Annual GHG emission reduction	tCO <sub>2</sub>	-	38.0

\*Emission factor of electricity is 0.9tCO<sub>2</sub>/MWh from IPCC 2006 (V2; C1 and C2)

### Case Study 8: Implementation of energy efficient screw compressor with VFD and PM motor

Laxmi Vishnu Silk Mills, Surat was incorporated in 1976. It has been a market trendsetter in creating wide range of cotton, polyester sarees & dress materials. Located in Bhestan, the unit is spread over an area of 50,000 sq ft with 100 skilled workers working in it. It has total "Grey to Pack in house facility." The unit has both dyeing and printing facility in their premises. The unit processes/manufacturers 32 lakh meters of finished dress material per month. In textile processing, compressed air forms one of the key utility which is used extensively in the process of dyeing and printing. The requirement for compressed air is met by the units by one or more compressor. Laxmi Vishnu Silk Mills was equipped with five reciprocating compressors. The compressors were installed at a common location and distributed to different equipment / process through a common receiver / header. Out of the five compressors, four were equipped with VFD. Based on the compressed air requirement of the plant, the compressor used to get automatically switched on and off. The compressors were equipped with individual air receivers with a total electricity load of 43 hp.

In 2019, the plant took a revolutionary step to replace their existing reciprocating compressor with a single screw compressor. The new compressor was energy efficient screw type and was equipped with VFD and 'Permanent Magnet' motor. The unit was able to save substantial energy consumption due to the new energy efficient screw compressor.

Particulars	UOM	Baseline	Post Implementation
Type of Compressor		Reciprocating	Screw with VFD & PM Motor
No. of compressor	Nos.	5	1
Cumulative motor ratings	kW	31.66	15
Total Capacity @ 7 bar pressure	cfm	52.73	15-88.6
Compressed air demand (based on study)	cfm	46.00	46.00
Operating hours per day	h/d	24	24
Operating days per year	d/y	330	330
Annual compressed air demand	-	364320	364320
Specific power consumption (weighted average)	kW/cfm	0.32	0.16
Annual power consumption	kWh/y	116582.4	58291
Annual power saving	kWh/y		58291
Weighted average electricity cost	Rs/kWh		6.87
Annual monetary savings	Rs in lakh/y		4.00
Investment	Rs in lakh		6.75
Simple pay-back	months		20
Annual energy savings	toe/y		5.01
Annual GHG emission reduction	tCO <sub>2</sub> /y		52.46

\*Emission factor of Electricity as per IPCC Guideline2006 (V2; C1 & C2) is 0.9 tCO<sub>2</sub>/MWh

\*\*Source: Implemented under GEF-UNIDO-BEE project titled "Promoting energy efficiency and renewable energy in selected MSME clusters in India"

## Technology No. 10: Energy Efficient Lightings

11

### 11.1 Baseline Scenario

Lighting accounts on average for about 15% of total electricity used in the units. Most of the conventional units use a variety of lighting fixtures like fluorescent tubes, incandescent & mercury vapour lamps, metal halide (MH) lamps, etc. in their offices and factory sheds. These conventional lighting fixtures consume a lot of energy. Also, lives of such fixtures are limited. Most of the units operate for whole day long and consume a significant portion of energy on account of lightings and fixtures. Also, due care is not given towards the lux level of different areas. Most of the units have sheds covered with asbestos sheet with negligible or no provisions for natural lighting.

### 11.2 Energy Efficient Technology

Recent developments in lighting technology combined with planned lighting control strategies can result in very significant cost savings, typically in the range of a third to a half of the electricity traditionally used for lighting. In new installations, energy efficient lighting costs little more to provide than the older less efficient kind. In retrofit situations, pay-back periods generally of between 1 and 5 years can be anticipated. Some of the important areas of energy conservation in a typical hand tool unit are:

- Replacement of conventional lighting with energy efficient LED lighting.
- Maximize the use of daylight to reduce the need for electric lighting. Roof lights are particularly efficient

as they disperse light evenly over the whole floor area. Provision of natural lighting in the units using translucent sheets in the shed is suggested.

- Painting of surfaces (including the ceiling) with matt colours of high reflectance to maximize the effectiveness of the light output. Light/bright colours can reflect up to 80% of incident light; dark/deep colours can reflect less than 10% of incident light.

### 11.3 Benefits of technology

Major benefits of replacing conventional lighting with energy efficient lights are:

- Energy savings
- Longer life
- Reduced operating and maintenance cost

### 11.4 Limitations of technology

Replacement of conventional lights will attract high investment.

### 11.5 Energy & GHG emission saving potential, Investment required & Cost benefits analysis

The following section provides the details of energy and GHG saving potential, investment required and cost-benefit analysis for replacement of conventional lights with LED lightings for a typical forging unit.

**Table 17: Cost benefit analysis of replacement of incandescent lighting with LED lighting**

Sl. No.	Particulars	Units	Baseline					After Implementation					Savings
			70	150	250	400	55	40	70	125	150	20	
1	Wattage	W	70	150	250	400	55	40	70	125	150	20	
2	No. of units of sodium vapour lights	No's	85	7	77	65		85	7	77	65		
3	No. of conventional lights						108					108	
4	Power consumption	W	5,950	1,050	19,250	26,000	5,940	3,400	490	9,625	9,750	2,160	32,765
5	Daily working hours	h/d	12	12	12	12	12	12	12	12	12	12	
6	Annual working days	d/y	365	365	365	365	365	365	365	365	365	365	
7	Energy consumption	kWh/y	26,061	4,600	84,315	113,880	26,017	14,892	2,146	42,158	42,705	9,461	143,511
8	Monetary cost	Rs/y	188,942	33,350	611,284	825,630	188,623	107,967	15,559	305,646	309,611	68,592	1,040,455
9	Investment @ Rs. 3000 per 40 W LED, Rs 5000 per 70 W LED, Rs 6000 per 125 W LED, Rs 7000 per 150 W LED and Rs 600 per 20 W LED for 10 hr per day for 365 days	Rs/y	1,271,800										
10	Simple payback period	Months	14-15										
11	Annual energy saving	toe/y	12.43										
12	Annual GHG emission reduction	tCO <sub>2</sub> /y	129										

\*Emission factor of coal as per IPCC guidelines is 0.9 tCO<sub>2</sub>/MWh for electricity from IPCC 2006 (V2; C1 and C2)

# 12 Technology No. 11: Scrap Processing

## 12.1 Baseline Scenario

Scrap is the major raw material in induction furnace units. The present practice suggests that a majority of units feed unprocessed scrap. The unprocessed or non-shredded scrap is fed with the charge through a



Figure 16: Compressed processed scrap

manual charging mechanism. Due to this charging practice, the bulk density of the scrap charge is low which results in air pockets (voids) between the scrap pieces that subsequently leads to low power density, ultimately increasing the heat/cycle time. The charging of unprocessed scrap leads to lower furnace efficiency, thereby increasing energy consumption.

## 12.2 Energy Efficient Technology

The size and shape of scrap plays an important role in running the EIF at full power/load, which is the best operating practice. The more the EIF runs at full power, lower will be total energy losses leading to lower specific energy consumption. The best practice is to use dense scrap charge for a faster melt rate and lower energy consumption. Small and dense scrap pieces are preferred for optimum results. To adopt this best practice, it is proposed to use shredded scrap in induction furnace. Thus, a 'shredding machine is an important technology package for induction furnace units.

A shredder is a machine that cuts large scrap pieces into smaller pieces and compresses them into pieces with higher bulk density. The shredder also removes rust and dust from the scrap. In the shredder, the scrap is cut into small pieces by specially designed hammers. The shredded scrap because of its higher bulk density increases the charging rate and also helps in better power coupling (means maximum power input which increases the melt rate) thus reducing heat/cycle time.

## 12.3 Benefits of technology

Major benefits of scrap processing are:

- High bulk-density of charge
- Better furnace efficiency
- Lower energy consumption

## 12.4 Limitations of technology

In-house scrap processing will require additional machines and land. Alternatively, processed scrap can be purchased directly from the market at a higher cost.

## 12.5 Energy & GHG emission saving potential, Investment required & Cost benefits analysis

The energy saving, GHG emission reduction and cost benefit analysis on annual basis for a shredding machine is tabulated below:

Table 18: Cost Benefit Analysis for in-house scrap processing

Sl. No.	Parameters	UOM	Value
1	Average production per heat	t/heat	1
2	Average slag generation per heat	%	5
3	Average charge input per heat	t/heat	1.05
4	Average heat time	h	2.00
5	Average number of heats in a day	Nos.	8
6	SEC of induction furnace (present)	kWh/t	650
7	Cycle time reduction with processed scrap	min	11
8	Percentage reduction in cycle time with processed scrap	%	9.17
9	New cycle time after using shredded scrap	h	1.82
10	New SEC of induction furnace	kWh/t	618
11	Electricity saving potential	%	5
12	Electricity saving potential	kWh/d	256
13	Electricity consumption in the shredding machine	kWh/d	75
14	Net electricity savings due to shredding machine	kWh/d	181
15	Number of operating days in a year	Nos.	300
16	Electricity saving potential	kWh/y	54,300
17	Electricity charges	Rs/kWh	7.5
18	Annual monetary saving	Lakh/y	4.07
19	Investment required	Rs in Lakh	8
20	Simple payback period	y	1.96
21	Energy saving potential	toe/y	4.67
22	GHG reduction potential	tCO <sub>2</sub> /y	48.87

\*Emission factor for electricity taken from IPCC guidelines as 1 MWh = 0.9 tCO<sub>2</sub> IPCC: 2006: V2 (C1 & C2)

## Technology No. 12: Replacement of Coil Cradle of Old Furnace

13

### 13.1 Baseline Scenario

In some induction furnace plants, furnaces are more than 8 to 10 years old. These furnaces have outdated coil cradle assembly while the latest furnaces have far more energy-efficient coil cradle assembly. Over time, the efficiency of old coil reduces as its shape gets distorted. Energy losses are high for old coil cradle assembly due to the following possible reasons:

- Non-uniform temperature gradient throughout the refractory
- Non-efficient shunt coverage
- Low current-carrying efficiency of the coil

### 13.2 Energy Efficient Technology

Replacement of an old coil cradle assembly of the induction furnace unit with a new and efficient design assembly can reduce electricity consumption during melting operation. Latest coil cradle assembly is equipped with specially designed curved magnetic shunts and covers around 80% of coil periphery, which minimizes stray losses and improves efficiency besides providing rigidity to coil cradle assembly. The shunts are carefully designed to provide a positive support to the coil. Cushioned insulating pads reduce

noise and vibration and hence enhance overall efficiency of the shunts. The coil cradle assembly with the latest design maintains uniform temperature gradient throughout the refractory, preventing overheating and enhances life of refractory

### 13.3 Benefits of technology

Major benefits of using new efficient coil cradle system are:

- Better furnace efficiency
- Lower energy consumption
- Enhanced lining life.

### 13.4 Limitations of technology

Design of coil cradle needs to be customized based on the furnace capacity, loading pattern and type of processed material.

### 13.5 Energy & GHG emission saving potential, Investment required & Cost benefits analysis

To understand the benefits of the technology, let us consider an induction furnace unit of 1 ton capacity.

**Table 19: Cost benefit analysis for a replacement of coil cradle**

Sl. No.	Parameters	UOM	Value
1	Average production per heat	t/heat	1
2	Average heat time	h	2.00
3	Average number of heats in a day	Nos.	8
4	SEC of induction furnace (present)	kWh/t	650
5	New SEC of induction furnace (with new EE coil cradle)	kWh/t	637
6	Electricity saving potential	%	2
7	Electricity saving potential	kWh/d	108
8	Number of operating days in a year	Nos.	300
9	Electricity saving potential	kWh/y	31200
10	Electricity charges	Rs/kWh	7.5
11	Annual monetary saving	Lakh/y	2.34
12	Investment required	Rs in Lakh	4
13	Simple payback period	y	1.71
14	Energy Saving potential	toe/y	2.68
15	GHG reduction potential	tCO <sub>2</sub> /y	28.08

\*Emission factor for electricity taken from IPCC guidelines 2006 (V2: C1 & C2) as 1 MWh = 0.9 tCO<sub>2</sub>

## 14 Technology No. 13: Ladle Preheating

### 14.1 Baseline Scenario

Induction furnaces are used to melt metal in many foundry and steel industries. In metallurgy, a ladle is a vessel used to transport and pour out molten metals. Ladles are often used in foundries and range in size from small hand carried vessels that resemble a kitchen ladle and hold 20 kilograms (44 lb) to large steel mill ladles that hold up to 300 tons (330 tons). Many non-ferrous foundries also use ceramic crucibles for transporting and pouring molten metal and will also refer to these as ladles. Ladle forms an important media to transfer energy.

Ladles are pre-heated slowly to remove the moisture from its lining and also to ensure that no cracks are developed. The ladle preheating is also necessary to withstand the temperature of the molten metal. Conventionally, ladles are dried using wood, coal, plastics, waste materials etc. Furthermore, the ladles are preheated using light diesel oil using crude method leading to lots of energy loss.

The partially heated ladle is filled with molten metal after tapping. This results in heating up of the lining of the ladle. This lowers the temperature of the molten metal. Therefore, the tapping temperature needs to be increased to get the required temperature at the time of pouring the metal into ingot molds or CCM. Due to this, cycle time is increased resulting in more electricity consumption per ton of production.

### 14.2 Energy Efficient Technology

The inefficiency in the conventional system can be reduced by using energy -efficient ladle pre-heater. The energy efficient ladle pre-heater is equipped with a complete lid cover; energy efficient high velocity burners; air-fuel ration controller and an inbuilt recuperator. The height of the lid

is adjusted using a motorized or hydraulically operated system. Once the ladle is placed, the swinging lid and height of lid is adjusted to completely cover the ladle. The lid is properly insulated to avoid any heat loss. The burner has an auto ignition system and an on-off control system which is controlled by PIC controller. The drying and pre-heating of the ladle is programmed based on requirement. The air-fuel ratio is automated to ensure optimized fuel consumption.

The burner is dual fuel type and suitable for liquid as well as gaseous fuels. Several interlocks are provided to ensure quality and safety of the ladle preheating process. This energy efficient ladle preheating ensures quick pre-heating up to 1,000°C instantly.

Ladle pre heater allows maintaining the bottom temperature of the ladle slightly higher than the top. The ladle is kept below the pre heater by the overhead crane or forklift. Then, the lid is placed on top of the ladle and the burner is lit with the help of natural gas. A high velocity flame makes sure there are no cold zones in the ladle.

The process takes about 15-20 minutes just before the tapping process.

### 14.3 Benefits of technology

The advantage of ladle preheating is as follows.

- Reduction in cycle time
- Better lining life of ladle
- Reduction in heat losses during transferring of ladle
- Better solidification of metal during pouring and casting

This helps reduce the tapping temperature by 15-20° C in the furnace.



Figure 17: Ladle preheating system



Figure 18: Preheated ladle

#### 14.4 Limitations of technology

It is important to place the ladle pre-heater close to the induction furnace to reduce the time of transfer.

#### 14.5 Energy & GHG emission saving potential, Investment required & Cost benefits analysis

To understand the cost-benefit analysis, let us consider an induction furnace unit of 1 ton capacity melting steel scrap.



## 15 Technology No. 14: Avoiding overfilling (metal above the coil level) of furnace during melting

### 15.1 Baseline Scenario

Most of the foundry units overfill the furnace above the coil height, to get increased production. Overfilling the feed above the coil height has its own disadvantages. The heat transfer mechanism takes place from coil to melt via conduction till the coil height. Above the coil height, heat transfer is from melt to melt (or metal to metal) instead of coil to metal. It takes some extra time for the heat and affects the SEC of the furnace. Improper filling and melting also leads to voids in the furnace.

### 15.2 Efficient Technology

This is an operating practice that needs to be checked to avoid overfilling of the furnace during melting. The operator working on the induction furnace needs to be trained, so that he or she fills the furnace up to the desired coil height for effective and faster heat transfer. Although overfilling is associated with extra production, extra production can also be achieved if the furnace is filled to the desired coil height. It will result in reduced heat time, thus allowing more heat per

day to ultimately result in more production. Apart from more production, it will also reduce the SEC of the operation as compared to the SEC during the overfilling.

### 15.3 Benefits of technology

The benefits of the technology are as follows.

- Reduction in energy consumption
- Better lining life of ladle
- Safer working environment

### 15.4 Limitations of technology

There are no limitations for adoption of this practice.

### 15.5 Energy & GHG emission saving potential, Investment required & Cost benefits analysis

To understand the cost-benefit analysis, let us consider an induction furnace unit of 1 ton capacity melting steel scrap.

**Table 20: Cost benefit analysis by avoiding overfilling of metals**

Sl. No.	Parameters	UOM	Value
1	Average production per heat	t/heat	1
2	Average heat time	h	2.00
3	Average number of heats in a day	Nos.	8
4	SEC of induction furnace (present)	kWh/t	650
5	New SEC of induction furnace (by maintaining charge till coil height)	kWh/t	637
6	Electricity saving potential	%	2
7	Electricity saving potential	kWh/d	108
8	Number of operating days in a year	Nos.	300
9	Electricity saving potential	kWh/y	31,200
10	Electricity charges	Rs/kWh	7.5
11	Annual monetary saving in Lakhs	Lakh/y	2.34
12	Energy Saving potential	toe/y	2.68
13	GHG reduction potential	tCO <sub>2</sub> /y	28.08

\*Emission factor for electricity taken from IPCC guidelines 2006 (V2: C1 & C2) as 1 MWh = 0.9 tCO<sub>2</sub>



## Technology No. 15: FRP blades in cooling tower

# 16

### 16.1 Baseline Scenario

The induction furnace unit has cooling towers to serve the cooling water needs of coil and panel cooling. The cooling water from the cooling tower comes to the pump suction by gravity and the pump supplies it to the coil and panel of the furnace. The cooling water from the furnace then goes back to the cooling tower. Existing cooling towers had induced axial flow fans with metallic/aluminium blades. It is well known that metallic/aluminium blades are heavier and need relatively greater starting torque.

### 16.2 Energy Efficient Technology

The use of Fiber Reinforced Plastic (FRP) blades instead of metallic/aluminium blades will save energy and improve the performance of the cooling towers owing to the better aerodynamic shape of its blades. The power measurements show that the fan with FRP blades consumes less power compared to the metallic blade fan. The difference in power consumption is around 25 to 30%. It is recommended to replace existing metallic/aluminium fan blades in the cooling tower with fibre reinforced plastic blades.

### 16.3 Benefits of technology

The benefits of the technology are as follows.

- Improved air flow due to the aerodynamic design
- Reduced energy consumption
- Increased life of fan

### 16.4 Limitations of technology

There are no limitations for adoption of this practice.

### 16.5 Energy & GHG emission saving potential, Investment required & Cost benefits analysis

The energy & GHG emission saving potential, investment required and cost-benefits analysis for replacement of metallic/ aluminum blade with FRP blades is given in the table below.

**Table 21: Cost benefit analysis for replacement of metallic/ aluminum blade with FRP blades in cooling tower**

Sl. No.	Parameters	UOM	Value
1	Rated power consumption of CT fan	kW	7.5
2	Existing power consumption of CT fan	kW	4.5
3	Operating hours per day	h	24
4	Number of operating days in a year	No.	300
5	Existing power consumption of CT fan	kWh/y	32,400
6	Anticipated savings with installation of FRP blades	%	25
7	Expected power consumption of CT fan after installing FRP blades	kWh/y	24,300
8	Annual energy saving	kWh/y	8,100
9	Electricity charges	Rs/kWh	7.5
10	Annual monetary saving	Rs in Lakh/y	0.60
11	Price of FRP blades	Rs in Lakh	0.50
12	Simple payback period	y	0.83
13	GHG reduction potential	tCO <sub>2</sub> /y	6.31
14	toe savings/yr	toe/y	0.69

\*Emission factor for electricity taken from IPCC guidelines as 1 MWh = 0.9 tCO<sub>2</sub>

# 17 Technology No. 16: Lid Mechanism in Induction Furnace

## 17.1 Baseline Scenario

Induction furnaces are mainly of two types, i.e. coreless furnace & channel furnace.

The coreless furnace, as the name suggests, has a highly conducting copper tube wound in the form of a helical coil. The coil is water-cooled and circulated, the water being recirculated and cooled in a cooling tower. It should be ensured that the lid fits properly and one should look out for maintenance issues. Regular maintenance must be done to ensure correct lid fit, therefore it will save energy that can be used otherwise. Radiation losses rise exponentially with the metal temperature. For e.g. 10% increase in molten metal temperature results in 33% increase of radiation losses; hence installation of a lid mechanism would lead to look out to genuine decrease in power costs.



Figure 19: Lid Mechanism in an Induction Furnace

## 17.2 Energy Efficient Technology

If one ton of iron is heated to 1,500°C, electrical energy required is 396 kWh. Losses in an induction furnace include thermal furnace losses, transmission losses, radiation losses, etc. The furnace efficiency accounts to 65-70%. 100 kWh-130 kWh of energy is lost in such losses. Installation of lid mechanism alone saves energy up to 25 kWh per ton that accounts to 4-6% of energy input.

## 17.3 Benefits of technology

The benefits of the technology are as follows.

- Saves radiation losses, improves furnace efficiency by 6%
- Promotes operational safety

## 17.4 Limitations of technology

There is no limitation for adoption of this practice other than one-time capital investment

## 17.5 Energy & GHG emission saving potential, Investment required & Cost benefits analysis

The opening of 750 kg induction furnace is circular with 460 mm diameter. Since one of the major heat losses in any induction furnace is radiation loss through opening, it is required to close the opening with insulating material and thus reduce radiation loss. In a typical induction furnace, radiation heat loss through opening will be 5-6% of the total electricity consumption.

Table 22: Cost benefit analysis for installation of lid mechanism in an induction furnace

Sl. No.	Parameters	UOM	Furnace without Lid	Furnace with Lid
1	Temperature of the Opening	°C	1,500	465
2	Ambient Temperature	°C	33.6	35.2
3	Total heat loss per heat	kWh/heat	24.45	11.16
4	Saving Potential per heat	kWh/heat		13.29
5	Total heats per day	Heats/d		21
6	Operational days in a year	day/y		300
7	Annual saving Potential	kWh/y		83,727
8	Annual monetary savings	Rs in Lakhs		6.2
9	Investment Required	Rs in Lakhs		3.50
10	Simple pay back	y		0.55
11	Annual Savings in toe	toe/y		7.2
12	GHG reduction potential	tCO <sub>2</sub> /y		75

\*Emission factor for electricity taken from IPCC guidelines 2006 (V2) as 0.9 tCO<sub>2</sub>/MWh

## Case Study 9: Installation of lid mechanism in induction furnace

K & K Foundry Pvt. Ltd, Kolhapur started foundry operation in 1996 and is producing low & medium size casting commodity for automobile and compressor manufacturing. The unit has installed one Dura-Line furnace of capacity 750 kg. The opening of 750 kg induction furnace is circular with 460 mm diameter. Based on an energy audit recommendation; the plant installed a hydraulically operated lid mechanism in their furnace. The temperature at the opening before implementation of lid mechanism was 1,500°C, and after the implementation was 465°C. Temperature drop is a clear indication of reduction in radiation loss through the opening. By successfully implementing this project, the plant achieved energy savings of nearly 83,727 kWh/y.

Sl. No.	Parameters	UOM	Baseline	Post Implementation
1	Temperature of the Opening	°C	1500	465
2	Ambient Temperature	°C	33.6	35.2
3	Total heat loss per heat	kWh/heat	24.45	11.16
4	Saving Potential per heat	kWh/heat		13.29
5	Total heats per day	Heats/d		21
6	Operational days in a year	Day/y		300
7	Annual saving Potential	kWh/y		83,727
8	Annual monetary savings	Rs in Lakhs		5.30
9	Investment Required	Rs in Lakhs		3.50
10	Simple pay back	y		0.66
11	Annual Savings in toe	toe/y		7.2
12	GHG reduction potential	tCO <sub>2</sub> /y		75

\*Emission factor for electricity taken from IPCC guidelines 2006 (V2) as 0.9 tCO<sub>2</sub>/MWh

\*\*Source: Implemented under GEF-UNIDO-BEE project titled "Promoting energy efficiency and renewable energy in selected MSME clusters in India"



## 18 Technology No. 17: Automation of Heat Treatment Processes

### 18.1 Baseline Scenario

Heat Treatment is a process of altering physical or metallurgical properties of a product that may lead to change in properties & performance, for e.g. metals are treated to improve toughness, increase hardness, refine grain structure, etc. The processes include multiple heating and cooling processes with quenching operations such as annealing, normalizing, hardening, carburizing, etc. Sometimes an item can be irregularly heat treated. For e.g. a furnace operator needs to charge the load manually and log the data which may lack precision.

Heat treatment furnace are used in some foundry applications.

### 18.2 Energy Efficient Technology

Substantial energy can be saved by installation of automation and control system in a heat treatment furnace. Under this system, the process parameters are controlled using a automation and control system and suitable softwares are programmed specifically to control heat treating processes. Equipment operators are not required to control the process or record the data in such case. A recipe based programming is done in the system in which the operator has to input the required data as per the type of heat treatment process. The

PLC based controller automatically controls the parameters as per the pre-set programme. The furnace parameters are controlled using solenoid valve in the fuel line and VFD in the air blower.

### 18.3 Benefits of technology

The benefits of the technology are as follows.

- Avoid manual error
- Avoids excess consumption of fuel
- Precise Control of Process

### 18.4 Limitations of technology

Harmonics are produced due to VFD, which can be managed with the help of capacitor banks and cable reactance.

### 18.5 Energy & GHG emission saving potential, Investment required & Cost benefits analysis

To understand the cost benefit analysis for installation of automation & control system in heat treatment furnace, let us consider a HSD fired heat treatment furnace of 0.7 kg/h capacity.

**Table 23: Cost benefit analysis for automation in heat treatment furnace**

Sl.No.	Parameter	UOM	HT furnace without automation	HT furnace with automation
1	Heat treatment furnace capacity	t/h	0.7	0.7
2	Specific energy consumption	l/t	140	126
3	Annual operating hours	h/y	3,200	3,200
4	Annual fuel consumption	kl/y	314	282.24
5	Annual fuel saving	kl/y	-	31
6	Annual monetary saving	Rs in lakh	-	19
7	Investment required	Rs in lakh	-	15
8	Simple Payback	y	-	0.8
9	Annual energy saving	toe	-	32
10	Annual GHG emission reduction	tCO <sub>2</sub>	-	105

\* Type of fuel : Diesel ; GCV: 11500 kCal/kg; Emission factor : 2.26 kg CO<sub>2</sub>/kg fuel (As per IPCC guidelines 2006 (V2))

# Technology No. 18: Replacement of Conventional Sand Plant with Energy Efficient Sand Plant

19

## 19.1 Baseline Scenario

Sand moulds are commonly used in iron foundries for producing castings of desired shape. A pattern of the object to be cast is formed initially. Generally, hard woods, metals or resins are used for making patterns by pattern makers. In the sand plant, coal dust and organic binders like bentonite powder or dextrin are added to silica sand. These components are mixed well with the help of mixer. In order to minimise the use of fresh sand, the moulding sand from previous pouring is also recycled and water and organic binders are added to it before it is reused. The sand management and moulding process is the second highest energy consumer in the typical foundry process with close to 15% of total energy share.



Figure 20: Energy share of critical processes in foundry industry

The sand handling system in a typical foundry unit can be categorized into sand management sand moulding and core preparation.

The sand management process includes sand mixing, sand cooling, sand conveying and dust collection. The sand moulding process involves mould making and mould handing. A conventional sand plant removes impurities from

the sand and de-waters it. Also, it requires a large number of drives for operations. The process is highly polluting and lower sand reclamation also causes a threat for the environment.

Conventional sand management plants consist of a large number of drives for handling as well as dust collection. Also the process is highly inefficient. Substantial energy saving potential exists for sand mixers, sand coolers, and sand conveying system.

## 19.2 Energy Efficient Technology

Energy efficient sand plant is designed to cater to small and medium foundries, and consists of a package of screening, charging, mixing, cooling and conveying systems for foundry used sand. The sand mixer is an important element of the sand handling system. Traditional sand mixers – mullers are operated in lower batch size of 250-300 kgs and have a lower output. The specific power consumption for such system is high. Significant energy can be saved by replacement of traditional sand mixer – mullers with energy efficient sand mixers. Different types of sand mixers are available which can be selected based on application. The power consumption for different types of sand mixers is tabulated below:

The sand cooling is also an energy intensive process in the sand handling system. Traditionally, rotary drum evaporative coolers are used for sand cooling. Most efficient sand coolers are available which includes ‘Mixer cum Cooler Evaporative Cooling’ system. Different types of systems available for cooling are tabulated below:

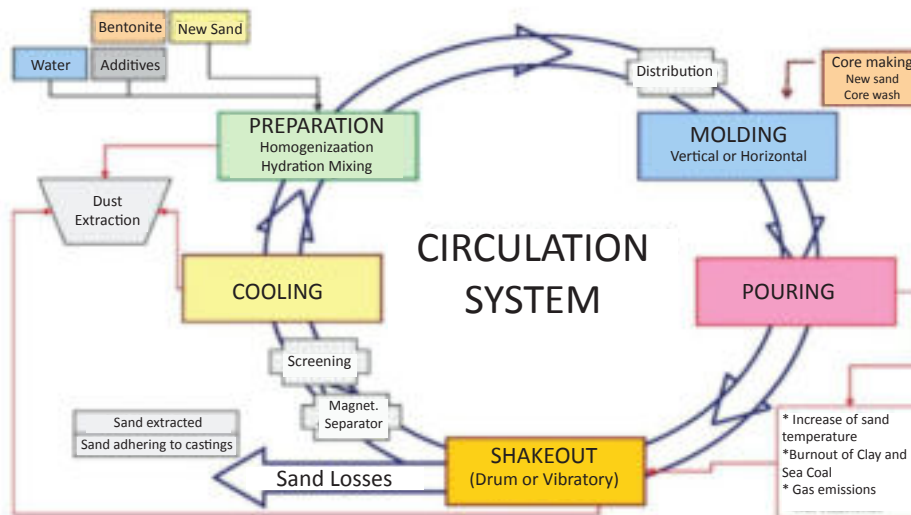

Figure 21: Typical sand handling system in foundries

Table 24: Types of sand mixers









						
	Units	Mixer-Muller	Fixed Rotor, Fixed Tank Intensive Mixer (Slow Speed)	Fixed Rotor, Fixed Tank Intensive Mixer (High Speed)	Rotating Tank, Fixed Rotor, Planetary Mixer	Fixed Tank, Planetary Tools with VFD
Batch	kgs	220	250	500	760	500
Process Time	Sec	360	180	100	120	140
Output	kg/h	2,200	5,000	18,000	22,800	12,857
Power	kW	7.5	13	67.5	68.5	33
Utilization	%	85%	85%	85%	85%	NA
Power Consumed	kWh	6.375	11.05	57.375	58.225	NA
Specific Power Consumption	kW/MT	2.90	2.21	3.19	2.55	1.60

Table 25: Types of sand coolers for foundries

					
	Units	Rotary Drum Evaporative Cooling	Fluidized Bed with Heat Exchanger Tubes	Eight Type Cooler Evaporative Cooling	Mixer cum Cooler Evaporative Cooling
Output	kg/h	10,000	1,000	22,000	20,000
Power -only cooling	kW	7.5	18.5	44	11
Utilization	%	85%	85%	85%	85%
Power Consumed	kW/h	6.375	15.725	37.4	9.35
Specific Power Consumption	kW/MT	0.64	15.73	1.70	0.47

Another important area in the sand management system is the sand conveying and dust collection system. In conventional process, bucket elevator system is used. The system consists of a large number of drives for transferring of sand and for dust collection. A typical bulk elevator plant consists of 21 nos. of motors for conveying and another 9

nos. of motors for dust collection. Alternatively, belt conveyor based sand conveying system can be used which uses 12 nos. of motors for conveying and 4 nos. of motors of dust collection. The replacement from bucket elevator plant to belt conveyor driven plant can lead to a saving of over 50%.

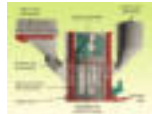
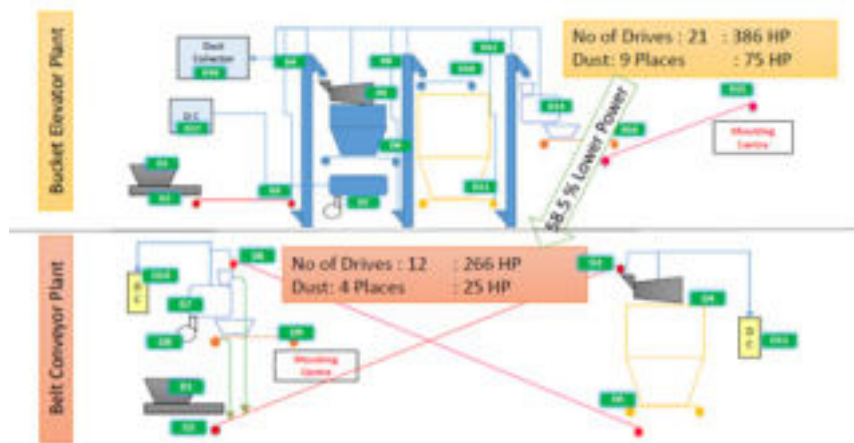

Figure 22: Comparison between bucket elevator plant and belt conveyor plant for sand handling

The energy efficient sand plant consisting of the mixer, cooler, and efficient conveying system can lead to a significant savings in terms of the rated motor capacity. A comparison between traditional plant and energy efficient plant is shown below:

### 19.3 Benefits of technology

The benefits of the technology are as follows.

- Weight reduction, consistency & rejection control
- Power Savings
- Low maintenance
- Pollution free environment
- Increase in productivity

### 19.4 Limitations of technology

Energy efficient sand plant is not economically feasible for lower capacity plants

### 19.5 Energy & GHG emission saving potential, Investment required & Cost benefits analysis

To understand the cost benefit analysis of the technology, let us consider a 40 MT/h EE Sand Plant that includes energy efficient sand mixer, cooler and belt conveying system.

**Table 26: Connected load for conventional vs EE sand plant**

Sl. No.	Particulars	Energy Efficient Sand Plant		Conventional Sand Plant	
		HP	% of total	HP	% of total
1	Sand Handling	66	22.7%	132.5	28.7%
2	Sand Mixing	195	67.0%	183.6	39.8%
3	Sand Cooling	15	5.2%	70	15.2%
4	Dust Collection	15	5.2%	75	16.3%
5	Sand Handling	66	22.7%	132.5	28.7%
	<b>Total</b>	<b>291</b>		<b>461.1</b>	

\*details for 40 MT/h capacity plant

**Table 27: Cost benefit analysis for energy efficient sand plant**

Sl. No.	Parameters	UOM	Conventional Sand Plant	Energy Efficient Sand Plant
1	Sand plant capacity	t/h	40	40
2	Installed power	hp	461	291
3	Average loading of motors	%	85	85
4	Average electrical energy consumption	kWh	288	182
5	Specific electrical energy consumption for sand processing	kWh/t	7.20	4.55
6	Energy saving	kWh/t	-	2.66
7	Sand to Metal ratio	Ratio	8	8
8	Connected load per tonne of casting	kW/t	57.63	36.38
9	Power tariff	Rs/kWh	7.5	7.5
10	Energy cost per tonne of casting	Rs/t	432	273
11	Monetary saving in casting cost	Rs/t	-	159
12	Annual production	t/y	4,800	4,800
13	Annual monetary savings	Rs in Lakhs	-	7.65
14	Investment	Rs in Lakhs	-	25
15	Simple Payback	y	-	3.27
16	Annual energy saving	toe/y	-	9
17	Annual GHG emission reduction	tCO <sub>2</sub> /y	-	92

\*Emission factor of electricity taken as 0.9 tCO<sub>2</sub>/MWh as per IPCC guideline 2006 (V2)

## 20

## Technology No. 19: Installation of Automatic Power Factor Controller (APFC)

### 20.1 Baseline Scenario

Power factor is the ratio of working power to apparent power. It measures how effectively electrical power is being used. A high power factor signals efficient utilization of electrical power, while a low power factor indicates poor utilization of electrical power.



Figure 23: APFC Panel

In foundry industry, most of the load is inductive in nature which results in lagging power factor. This leads to loss and wastage of energy which results in high power bills and heavy penalties from electricity boards. When equipment operates with lower power factor, it may lead to:

- Penalty in electricity bills
- Efficiency loss of equipment
- Power Consumption, hence increased energy cost

### 20.2 Energy Efficient Technology

Issues due to low power factor can be increase power demand for the same load, drawing more current, increasing copper loss in transformer and also increasing losses in distribution cable. To avoid the low power factor in the energy bill, it is proposed to introduce an Automatic Power Factor Control (APFC).

A capacitor is used as a basic storage device to store electrical charges and release it as and when it is required by the circuit.

The simple solution to maintain the power factor in required range is to connect or disconnect the power factor correction capacitors. Manual switching is just impossible for rapidly fluctuating loads and hence an automatic control system is required which continuously monitors the power factor and make appropriate corrections.

The automatic power factor controller is connected parallel to the transformer terminals. The purpose of the APFC is to maintain the power factor close to unity at varying loads. The APFC comes with a microprocessor based controller with features of sensing voltage and current and accordingly switch on and off the contactors for the capacitor to maintain the desired range of power factor. The APFC cables and transformer terminal cable links are connected with the same bus bar link with the sensing CTs connected to the transformer side of the cable. When we switch on the APFC panel, it automatically senses the power factor and switches on the capacitor banks as required.

### 20.3 Benefits of technology

The benefits of the technology are as follows.

- Reduced electric utility bills
- Increased system capacity
- Improved voltage
- Reduced losses

### 20.4 Limitations of technology

No limitations for this technology

### 20.5 Energy & GHG emission saving potential, Investment required & Cost benefits analysis

To understand the benefit of installation of automatic power factor controller (APFC) panel let us consider a unit with 120 KW connected load.

Table 28: Cost benefit analysis of APFC panel

Sl. No.	Parameters	UOM	Without APFC Panel	With APFC panel
1	Total connected load	kW	120	120
2	Power Factor	-	0.95	0.99
3	Capacitor bank required	kVAr	-	66
4	Annual energy savings	kVAh	-	4,000
5	Annual monetary saving (due to saving in penalty)	Rs in Lakhs	-	6
6	Investment required	Rs in Lakhs	-	4
7	Simple payback	y	-	0.66



## Technology No. 20: Installation of Servo Voltage Stabilizer

21

### 21.1 Baseline Scenario

Fluctuations in energy voltage are a common problem with most industries. All electrical and electronic systems are designed and manufactured to operate at maximum efficiency with a given supply voltage, called the nominal operating voltage. Voltage fluctuations not only lead to inefficiency in the operations of the machine but also the risk of equipment failure.

### 21.2 Energy Efficient Technology

The stabilizers are electronic devices responsible for correcting the voltage of the electrical power supply to provide a stable and secure power supply to equipments. The main component of a servo voltage stabilizer includes continuous variable transformer used for phase voltage corrections, buck/boost transformers to increase or decrease the voltage; servo motor, a microprocessor based control circuitry and a contactor which helps to trip the system in case of abnormal voltage variation. Voltage received from main at input is continuously sensed and in case of voltage variation, the microprocessor gives trigger to the motor driver. The motor driver accordingly moves the servo motor across winding of autotransformer so as to increase or decrease no of winding and hence the voltage across primary of buck

boost transformer. When there is a change in voltage across primary of buck boost transformer then induce voltage across its secondary also changes to the desired output voltage of servo stabilizer thus stabilizing the output voltage.

### 21.3 Benefits of technology

Benefits of a servo voltage stabilizer include:

- Increased useful life of equipment;
- Reduces malfunctions rate of equipment;
- Maintains a stabilized power supply;
- Attenuates noise, interference and lightning

### 21.4 Limitations of technology

No limitations for this technology

### 21.5 Energy & GHG emission saving potential, Investment required & Cost benefits analysis

To under the cost benefit analysis for installation of servo voltage stabilizer, let us consider a unit with 685 kVA maximum demand. The benefits of the installation of the technology are tabulated below:

**Table 29: Cost Benefit analysis of Servo Stabilizer**

S. No	Parameter	UOM	Without Voltage Stabilizer	With Servo Voltage Stabilizer
1	Maximum Load	kW	594.1	594.1
2	Maximum Load	kVA	685	685
3	Average Voltage	V	437	407
4	% reduction In voltage	%		6.9%
5	% reduction in Energy consumption	%		13.3%
6	Annual Electricity from Grid as per bills	kVAh/y	2,302,300	-
7	Average Power Factor of System	Basis : Bill/ Measured	1	1
8	Annual Electricity from Grid	kWh/y	2,301,720	2,301,720
9	Savings Estimate from other EPIAs	kWh/y	-	133695
10	% of total Electricity from Grid	%	99.51	99.51
11	Actual Energy Considered for Voltage Regulation	kWh/y	-	2,168,680
12	Actual Energy Consumption after Voltage Regulation	kWh/y	-	1,881,141
13	Efficiency of Servo Stabilizer	%	-	95%
14	Assumption : Period for Which Voltage Regulation is required	Months/y	-	12
15	Net Saving from Voltage Regulation	kWh/y	-	273,162
16	Electricity tariff from Grid	Rs./kWh	-	7.5
17	Annual Monetary Saving	Lakh Rs.	-	20.4
18	Sizing of Servo Stabilizer	kVA	-	625
19	Rating Of Servo Stablizer	kVA	-	650
20	Investment Estimate	Lakh Rs.	-	15
21	Payback	Months	-	8.8
22	Annual energy saving	toe	-	23
23	Annual GHG emission reduction	tCO <sub>2</sub>	-	246

\* Type of fuel : Electricity ; GCV: 860 kCal/kWh; Emission factor : 0.9 tCO<sub>2</sub>/MWh (As per IPCC guidelines 2006 (V2))

22

Technology No. 21: Replacement 6-pulse power system with 12-pulse/24-pulse power system in induction furnace

22.1 Baseline Scenario

Presently most of the foundry industries in operation do use induction furnaces due to the significant advantages offered by them as compared to the other types of furnaces. However the major problem with this kind of furnaces from an electrical point of view is the inductive and non-linear nature of the furnace load. This is responsible for generation of considerable harmonic distortion and pollution in the supply system. The cause is within the induction furnace design and operation itself, because

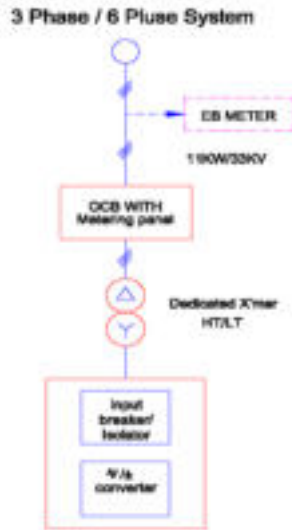

Figure 24: 3 Phase 6 Pulse System

it is a known fact that the order of harmonics and hence the magnitude of distortion depends upon the number of converter pulses used in the furnace power supply system.

For controlling and preventing the harmonics/waveform distortion problems, rules and norms concerning permissible limits of voltage and current harmonic distortion do exist. However to comply with these legislations and reduce harmonic distortion below the established permissible level, proper corrective actions have to be taken. Most of the foundry clusters are equipped with 6-pulse converter system which results in high harmonic distortion, leading to higher specific energy consumption.

22.2 Energy Efficient Technology

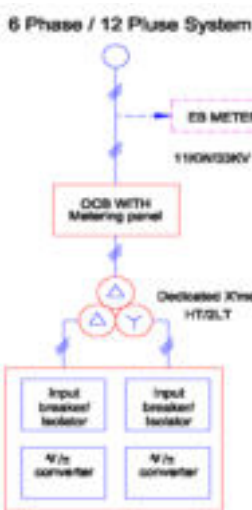

Figure 25: 6 Phase / 12 Pulse System

Total harmonic distortion, or THD is a common measurement of the level of harmonic distortion present in power systems. With the 6-pulse power supply system, the 5th and 7th order harmonics are significant, and filtering is often needed. Harmonic current in the system increases hysteresis losses and eddy current losses. These losses raise the system's operating temperature, which can derate performance and reduce the life of the system.

A 12-pulse rectifier uses two 6-pulse rectifiers in parallel (12 diodes) to feed a common DC bus. A transformer with one primary and two secondary windings creates a 30 degree phase shift between the two current waveforms, which eliminates the 5th and 7th harmonics and reduces current THD to between 10 and 15 percent.

Eliminating virtually all harmonics requires a 24-pulse rectifier, which consists of two 12-pulse rectifiers in parallel and two 3-winding transformers. The transformers provide a voltage waveform offset of 15 degrees, which cancels most low-frequency harmonics.

Conversion of the exiting 6-pulse to 12-pulse/24-pulse power supply system thus leads to significant reduction in Total Harmonic Distortion (THD) for the induction furnace system. It also improves the power factor improving the system efficiency and reducing the specific energy consumption.



Figure 26: 12 Phase / 24 Pulse system

22.3 Benefits of technology

Benefits of the system include:

- Reduction in Total Harmonic Distortion (THD)
- Increase in power factor
- Better life of equipment
- Improved system efficient, lesser losses

22.4 Limitations of technology

The conversion to 12-pulse & 24-pulse power supply system is a capital intensive process.

22.5 Energy & GHG emission saving potential, Investment required & Cost benefits analysis

To understand the cost benefit analysis for conversion of 6-pulse to 12-pulse power supply system, let us consider a 2 tonnes induction furnace:

**Table 30: Cost Benefit Analysis of 12 pulse/24 pulse power system in induction furnace**

Sl. No.	Parameters	UOM	Value
1	Average production per heat	t/heat	2
2	Average number of heats in a day	Nos.	12
3	Annual production	t/y	7,920
4	SEC of induction furnace (present)	kWh/t	650
5	New SEC of induction furnace (with preheated ladle)	kWh/t	585
6	Electricity saving potential	%	10
7	Electricity saving potential	kWh/d	780
8	Number of operating days in a year	Nos.	330
9	Electricity saving potential	kWh/y	2,57,400
10	Electricity charges	Rs/kWh	7.5
11	Annual monetary saving	Lakh/y	19.35
12	Investment required	Rs in Lakh	25
13	Simple payback period	y	1.29
14	Energy saving potential	toe/y	22
15	GHG reduction potential	tCO <sub>2</sub> /y	231

*\*Emission factor of electricity taken as 0.9tCO<sub>2</sub>/MWh as per IPCC Guideline 2006 (V2)*



## Conclusion

The compendium consists of a list of energy efficient and renewable energy technologies applicable for the micro, small and medium enterprises (MSME) units in the targeted sectors. The listed technologies have been grouped into three broad categories of 'low investment', 'medium investment' and 'high investment' technologies. In most cases, MSME units use old and obsolete technologies leading to higher energy consumption. There is a significant potential for cost savings through the adoption of these energy efficient and renewable energy technologies. The compendium consists of a list of commonly applicable energy efficient and renewable energy technologies in the cluster. These technologies need to be customized based on individual unit's requirements. The techno-commercial feasibility depends on the process, operational conditions and other variable parameters in a particular unit. Also, all technologies may not be applicable in every unit.

In order to achieve maximum benefits of a particular technology, the same should be supported by good operating practices. Continuous capacity enhancement of the operators is important to achieve maximum benefits from technology up-gradation.

Micro, Small and Medium Enterprises (MSMEs) are the growth accelerators of the Indian economy, contributing about 30% of the country's gross domestic product (GDP). Under such scenario, it becomes important for these industries to adapt to efficient technologies and practices. Accelerated adoption of energy efficient and renewable energy technologies can ensure a cost effective and energy efficient production process. With an overarching objective of bringing in a transformational change in the sector, the technology compendium provides information on options available to do so.

The Coimbatore foundry cluster consists of over 200 MSME units with products catering to a variety of industrial sectors. The sector comprises two broad categories of units based on technology route adopted for melting. This includes the 'cupola' based units and the 'electric induction furnace' based units. While a large number of units have already taken a step forward towards upgrading themselves to new technologies, a section of the cluster still uses traditional technologies like 'cupola' furnace. The growth in the Cupola based units is restricted by the lower market demand, lesser availability of resources and lower credit facility. A holistic approach has been taken in developing the compendium to cater to all sections of industry.

The implementation of the technologies listed in the compendium will lead to multi-fold benefits including improvement in the factory environment, productivity, energy performance as well as the environmental sustainability. The

technologies listed in the compendium have saving potentials in the range of 20% to 35%. The technologies discussed in the document include:

Low Investment Technologies (less than Rs 2 lakhs):

- Replacement of old motors with IE-3 EE motors
- Energy efficient blower
- Energy efficient lightings
- Energy efficient compressed air network
- Replacement of in-efficient pump with high EE pump
- Avoiding overfilling of furnace crucible
- FRP Blades in cooling tower
- Lid mechanism in induction furnace

Medium Investment Technologies (up to Rs 10 lakhs):

- Energy efficient screw compressor with VFD and PM motor
- Scrap processing
- Replacement of coil cradle
- Energy efficient ladle preheater
- Automation in heat treatment furnace
- Installation of APFC
- Installation of servo voltage stabilizer

High Investment Technologies (more than Rs 10 Lakhs):

- Replacement of single blast cupola (SBC) with divided blast cupola (DBC)
- Replacement of cupola with induction furnace
- Installation of solar PV system
- Replacement of thyristor-based induction furnace with IGBT based induction furnace
- Conversion from 6-pulse to 12-pulse / 24-pulse power system
- Energy efficient sand plant

Through this technology compendium the project hopes to maximize the environment benefits that would lead to Energy savings and GHG emission reduction. The project titled "Promoting energy efficiency and renewable energy in selected MSME clusters in India" provides a unique opportunity to the MSME units to progress towards a sustainable future.

## List of Vendors

Sl. No.	Name	Address	Contact person	Phone No.	Email id
<b>Technology : Divided Blast Cupola</b>					
1.	P S Trading Co	NH6,Pakuria,PO:Lakhanpur, Howrah- 711323, West Bengal,	Mr. Pinaki Chakraborty	+91 9433025900 / 9830700516	pstchi@gmail.com
2.	Vitthal Enterprise	No. 36-37, Gajanand Estate, Nagarwel Hanuman Road, Rakhial, Ahmedabad - 380023, Gujarat	Mr. Vasant Panchal	+91- 9825285536 / 9825346199	info@vitthalenterprise.com
3	Vijay Engineers & Fabricators	C-3 & C-4/1/2, MIDC, Shirol, Beside Police Station, Kolhapur-416122, Maharashtra, India.		+91 – 9850485504 / 78880 34203	response@vijayfoundryequipment.com
<b>Technology: Screw Compressor</b>					
1	Ingersoll Rand (R D Dutta & Co. Pvt. Ltd. - New Delhi)	302, Rattan Jyoti, 18, Rajendra Place New Delhi 110008	Mr. Sathis Yadav	+91-9310835335	sathis_yadav@irco.com
2	Atlas Copco (Global Airtech Systems)	Office:-219, Akshar Arcade, Opp. Memnagar Fire Station, Nr. Vijay Cross Road, Ahmedabad -380014. Tel: - 079-26563142, Email: - info@globalairtechsystems.com;	Mr. Archit Shah	9824035330	timesmarketing@vsnl.com
3	Elgi	Trichy Road, Singanallur, Coimbatore – 641005, Tamilnadu,	Mr. Manish Sharma	9717294736, 011-25153644 / 25928095 / 25928593	manishs@elgi.com
4	Venus Compressors Pvt. Ltd.	60/3,Diamond Industrial Estate, N.H.8.Nr.Unnati Industrial Corporation, Nana Chiloda,Naroda,Ahmedabad -382330	Mr. Pankaj Chauhan	9825200073	mkt@venuscompressor.com
<b>Technology: Energy Efficient Pumps</b>					
1	Grundfos Pumps India Pvt. Ltd.	Third Floor, Plot No. 55 P, Institutional Area, Sector-44 Gurugram-122003	Mr. Abhishek Sharma	+91 7338787808	abhishek@grundfos.com
<b>Technology : IE 3 class efficiency energy efficient motor</b>					
1	Bharat Bijlee	Electric Mansion 6th Floor Appasaheb Marathe Marg, Prabhadevi Mumbai 400 025		+91 22 2430 6237 / 6071	info@bharatbijlee.com
2	Crompton Greaves	Church Road, PO BOX 173 Jaipur 302 001, Rajasthan, India	Mr. Sunil Dutta	+91 141 3018800 /01	sunil.dutt@cgglobal.com
3	Siemens Limited	Birla Aurora, Level 21, Plot No. 1080, Dr. Annie Besant Road, Worli, Mumbai – 400030 India		1800 209 1800	
<b>Technology : Electric Induction Furnace</b>					
1	Inductotherm (India) Pvt. Ltd.	Plot No. SM-6, Road No.11 Sanand-II, Industrial Estate, BOL Village, Sanand Ahmedabad- 382170		+91 937 457 8586	sales@inductothermindia.com

Sl. No.	Name	Address	Contact person	Phone No.	Email id
2	Plasma Induction	330/1p,Hajipur,Nr JKLaxmi Cement,Ta. Kalol, Dist. Gandhinagar, Via Ahmedabad Vadsar Road,382721		+91 99042 25550	sales@plasmainduction.com
3	Oritech Solutions	Plot No. 4 & 4P, Swastik Industrial Estate, Opp. Aarvee Denim, Vil. Sari, Changodar - Bavla Highway, Ta. Sanand, Dist. Ahmedabad - 382220 Gujarat,		+91-9374764116 / +91-9374772650	info@oritech.in
4	Electrotherm India Pvt. Ltd.	Survey No. 72 Palodia (Via Thaltej) Ahmedabad – 382115 Gujarat, India.		+91-2717-660550	mkt@electrotherm.com
<b>Technology : Solar PV System</b>					
1	Mas Solar System Pvt. Limited	153, SIDCO Industrial Estate Malumichampatti Post, Coimbatore Tamil Nadu, INDIA - 641050		+91 9585556502 / 9585556504	marketing@massolarsystems.com
2	Dev International	15,Doctor Thottam, Kalapatti - Kurumbapalayam Road, Coimbatore - 641048.		+91 887 044 5566, +91 984 317 9797	dev@devsolar.com
3	Aadhi Solar	2-C/2, Kumaran Nagar, Opp VKR Kalyana Mandapam, Vilakuruchi Post, Coimbatore 641035		+91-9378133000	sales@aadhisolar.com
4	Sun Shell Power	DLF Galleria , Office No: 714 , 7th Floor Premises No 02-0124, Action Area 1B, Newtown, Kolkata, West Bengal 700156		033-40068535	info@sunshellpower.com
5	Modern Solar Private Limited	2/5, Sarat Bose Road, Sukhsagar, Building- 2 , Floor- 2, Kolkata 700 020		+91 903 805 1230	info@modernsolar.in
<b>Technology : APFC &amp; Servo Voltage Stabilizer</b>					
1	PS Power Controls	No. 3 / 4 Thirumalai Raja Street, Aynavaram, Chennai 600023	Mr. L. Hari Krishnan	+91-9840875082	harish@pspowercontrols.com
2	VM Control System	New No. 6, Old No. 32, Poonamallee Road, Chennai 600032		+91-9791044709	vmcontrolsystem@yahoo.com
3	Sakthi Electrical Controls	No. 72, Rabiranath Tagore Road, RVS Nagar, Ganapathy, Coimbatore - 641006, Tamil Nadu, India	Mr. Thilagar Shanmugam	+91-8048601238	
4	Standard Power Controls	211/3B Anjugamnagar Chinnavedampatti Coimbatore 641049		+91-9944976750	techmaxbe@gmail.com
5	Das & Company	B/36/1A/H/1/14, Pulin Khatick Road, Ashirbad Apartment, Ground Floor, Tangra, Kolkata - 700015		+91-9883570333	info@dasnko.net

Sl. No.	Name	Address	Contact person	Phone No.	Email id
6	A C Power System	1st Floor, 1419, Nilachal Complex, Row-5, N.S.C Bose Road, P.O. Narendrapur Kolkata-700 103		(033)2428-7291 /2477-3051	acpowersystemmarketing@gmail.com
<b>Technology : Energy Efficient Sand Plant</b>					
1	Rhino Machines Pvt. Ltd.	Plot No 1A & 1B, GIDC Phase II, GJ SH 83, Vithal Udyognagar, Anand, Gujarat 388325	Mr. Aravindanabhan TS	+91-9244658898	rhino@rhinomachines.net rhinoaravind@gmail.com
2	Wesman Engineering	1B, Kamaraj Square 8 Valayapathy Street, Mogappair East Chennai 600037, India		+91 (44) 2656 1300, 2656 1775	chennai@wesman.com



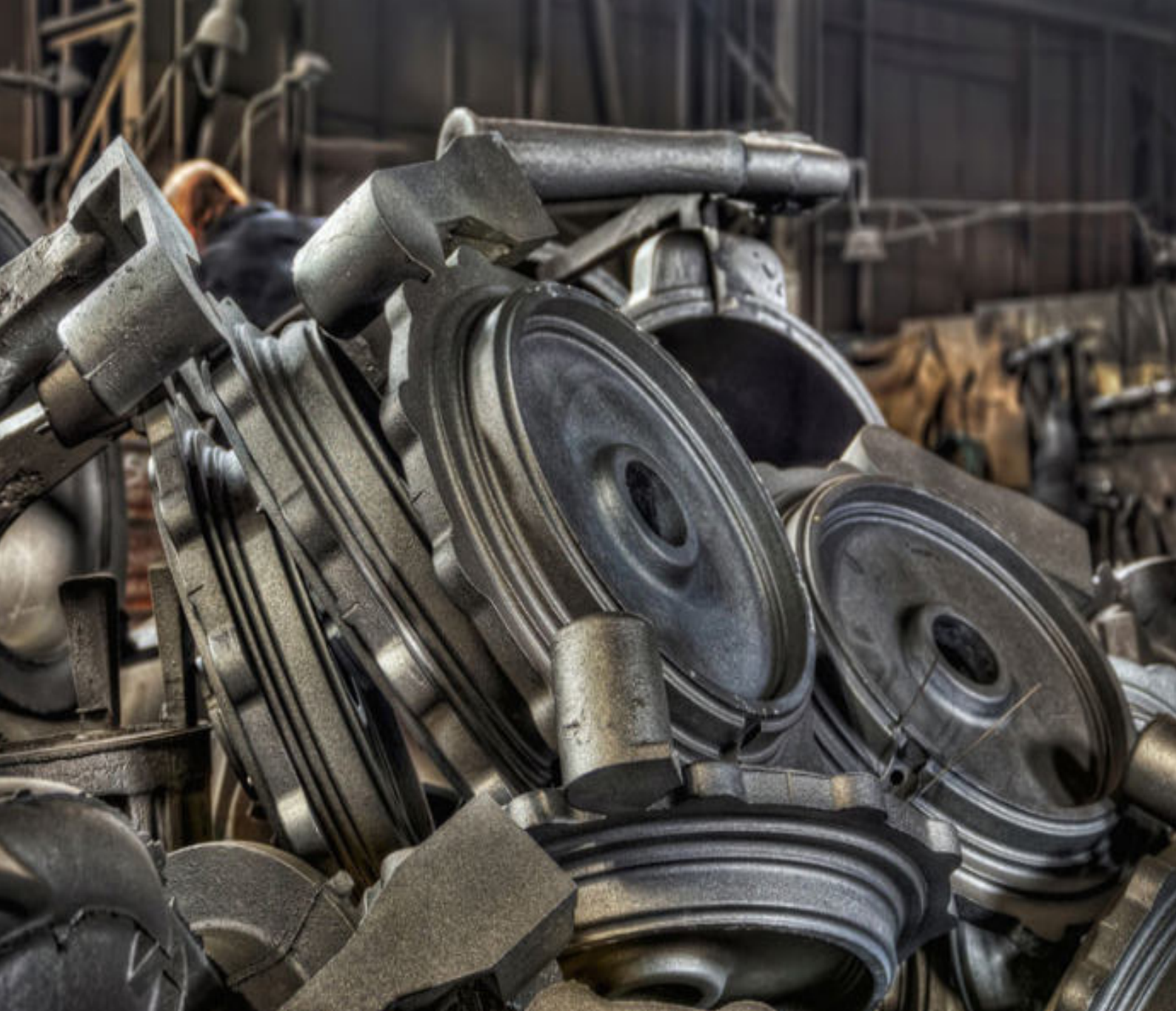

For more details, please contact



**UNITED NATIONS  
INDUSTRIAL DEVELOPMENT ORGANIZATION**

Vienna International Centre  
P.O. Box 300 · 1400  
Vienna · Austria  
Tel.: (+43-1) 26026-0  
ENE@unido.org  
www.unido.org

UNIDO  
Regional Office in India  
UN House  
55, Lodi Estate  
New Delhi - 110 003, India  
office.india@unido.org



**Bureau of Energy Efficiency**  
Government of India, Ministry of Power

4th Floor, Sewa Bhawan,  
R. K. Puram,  
New Delhi- 110 066, India  
Tel: (+91) 011 2617 9699-0  
gubpmu@beenet.in  
www.beeindia.gov.in